



DA200

AC Servo System



Content

Introduction	2
Servo system family	3
Outstanding product performance.....	4
Powerful functions	5
Intelligence	7
Humanized operation software	9
Application cases	11
Servo drive configuration table	13
Servo drive model instruction	14
Technical parameters of servo drive	16
Servo motor model instruction.....	18
Technical parameters of servo motor	19
Servo motor installation dimension.....	21
Servo motor torque-speed characteristic.....	27
Servo motor power cable model.....	29
Servo motor power cable distribution.....	30
Servo motor encoder cable model.....	31
Servo motor encoder cable distribution.....	32
User interface	33
System wiring	34
Standard wiring diagram.....	35
Servo system ordering guideline.....	37
Other INVT industrial control products	38





/ Introduction

DA200 series high performance AC servo system is our flagship product aiming at assisting clients in industry upgrade and fulfilling demanding market needs.

Through integrating industry needs with leading control performance, it achieves the perfect combination of servo system and application environment.



Servo system family

Comprehensive product series for applications in various networks.
Abundant supporting products for constructing systems as needed.

Drive layer



DA200 versatile high performance AC servo system



DB100 versatile AC servo system



MH600 spindle servo system



MH800 electrical-hydraulic servo system



MH500 hydraulic servo system



SL330 electronic take-up dual let-off system



SL320 loom electronic take-up let-off system



SL310 loom electronic let-off system



Dual shaft servo system



ML510 simple-type spindle servo system

Execution layer



Small power servo motor



Middle power servo motor



Servo fluid-cooled spindle motor



Synchronous motor

Outstanding product performance

Industry-leading speed response

Speed response frequency can be up to 2.0kHz, which greatly improves the processing speed, shortens rectification time and gives full play to the high-end mechanical performance.

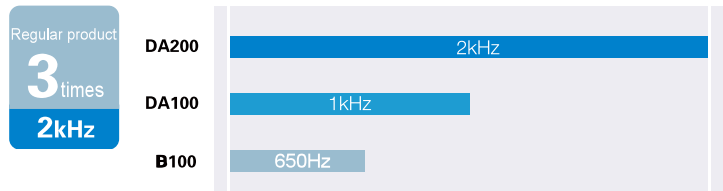

Excellent positioning precision

Equipped with 23-bit high resolution encoder, the precision of which is 64 times higher than the regular 17-bit encoder.

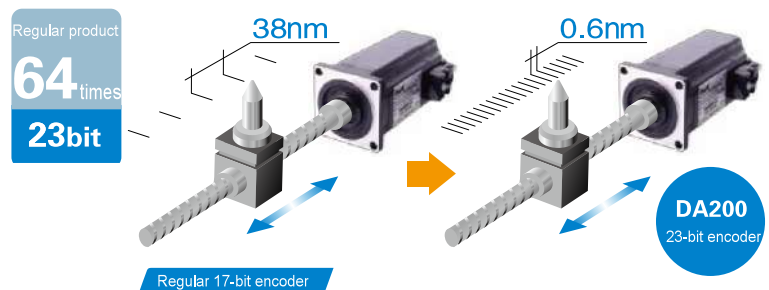

I/O signal configuration

10 digital inputs and 6 digital outputs can be configured freely by parameters through ServoPlover software interface, which is both easy and convenient.

Channel	Func Select	Active Mode	Communication Con...	Communication State	State Feedback
Type: Digital Input					
Digital Input1	0x03:Servo on	High Low	Enable Disable	Invalid	Invalid
Digital Input2	0x0D:Zero speed ...	High Low	Enable Disable	Invalid	Invalid
Digital Input3	0x04:Fault recover	High Low	Enable Disable	Invalid	Invalid
Digital Input4	0x16:Emergency	High Low	Enable Disable	Invalid	Invalid
Digital Input5	0x19:Electronic g...	High Low	Enable Disable	Invalid	Invalid
Digital Input6	0x1A:Electronic g...	High Low	Enable Disable	Invalid	Invalid
Digital Input7	0x01:POT	High Low	Enable Disable	Invalid	Invalid
Digital Input8	0x02:NOT	High Low	Enable Disable	Invalid	Invalid
Digital Input9	0x07:Position erro...	High Low	Enable Disable	Invalid	Invalid
Digital Input10	0x08:Pulse input ...	High Low	Enable Disable	Invalid	Invalid
Type: Digital Output					
Digital Output1	0x01:Servo ready	High Low	Enable Disable	Invalid	Valid
Digital Output2	0x03:Fault output	High Low	Enable Disable	Invalid	Invalid
Digital Output3	0x07:In position	High Low	Enable Disable	Invalid	Invalid
Digital Output4	0x0D:Speed zero	High Low	Enable Disable	Invalid	Valid
Digital Output5	0x05:Brake off	High Low	Enable Disable	Invalid	Invalid
Digital Output6	0x0E:Torque limit...	High Low	Enable Disable	Invalid	Invalid

Powerful functions

Full closed-loop control

Support connection with external encoder or grating ruler installed on the load end to realize full closed-loop control, reduce back clearance impact caused by mechanical drive and improve terminal positioning precision of the machine.

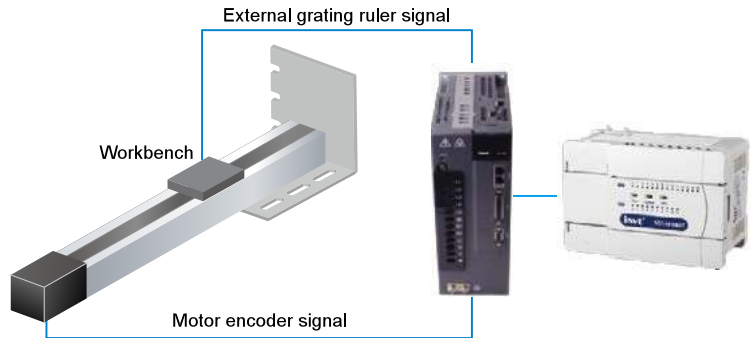

Internal position control

Realize 128-step internal position control by combination of input terminal commands (external I/O or bus control). For motion control, you can simplify PLC unit and optimize external user configuration plan via internal program design.

PtP0.00	Control word of 00 step	Setting range	Default	Unit	Available mode
		0-0x7FFFFFFF	0	-	P

Overall instruction:

Data bit	Name	Function
Bit0~3	MODE	Step running mode
Bit4~7	OPT	Step attribute
Bit8~11	ACC	Acc/dec time index
Bit12~15	SPD	Target speed index
Bit16~19	DLY	Delay time index
Bit20~23	CYL	Cycles of current step
Bit24~30	JMP	Jump to the next step

Mode instruction:

Mode	Instruction
0	Stop after current step is executed
1	Jump to the next step after current step is executed
2	Stop after cycle execution, invalid if CMD=1
3	Jump to next step after cycle execution, invalid if CMD=1

OPT instruction:

Data bit	Name	Function
Bit4	INS	Interrupt, this step is entitled to interrupt the execution of steps under executing or to be executed.
Bit5	OVLP	Overlay, this step can be combined and overlaid with the next one for execution.
Bit6~7	CMD	Position command type, 0: Incremental, 1: Absolute

■ ECAM function

- Cam outline can be up to 1000 points;
- Automatic smoothness gap compensation between two points in the curve to ensure smooth mechanical operation;
- ServoPlover software supports cam planning and function setup;
- Suitable for flying cutting, flying saw and other master/slave applications.

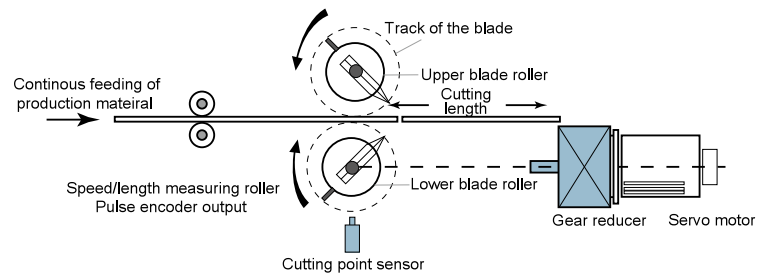

■ Various communication interface

Support multiple bus communication protocols eg Modbus, CANopen, PROFIBUS-DP, EtherCAT, Motionnet and etc. Remote multi-shaft high speed synchronous control can be realized via networking.



■ Load inertia identification

Equipped with online and offline inertia identification modes. Automatically identify gain parameters in the system to shorten system rectification time.

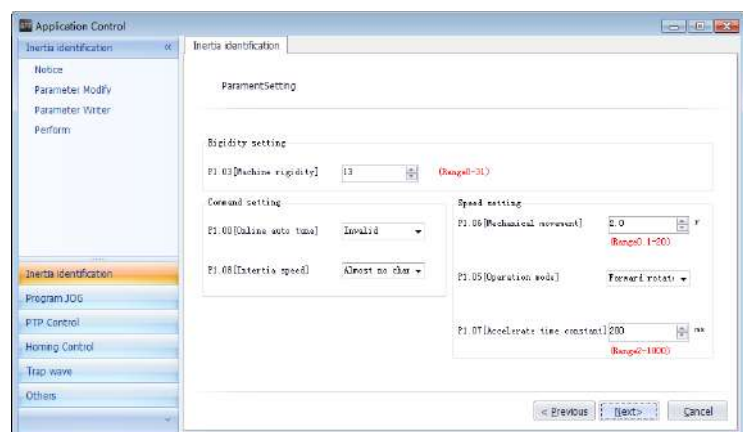

Intelligence

Automatic/manual notch filter

Support auto setup of notch filter and auto vibration detection without the need for measuring vibration frequency.

Abnormal noise and vibration caused by mechanical device can be greatly lowered down via this notch filter.

DA200 series products carry four notch filters with 50~5000Hz set frequency and adjustable depth (two of which can be set automatically).

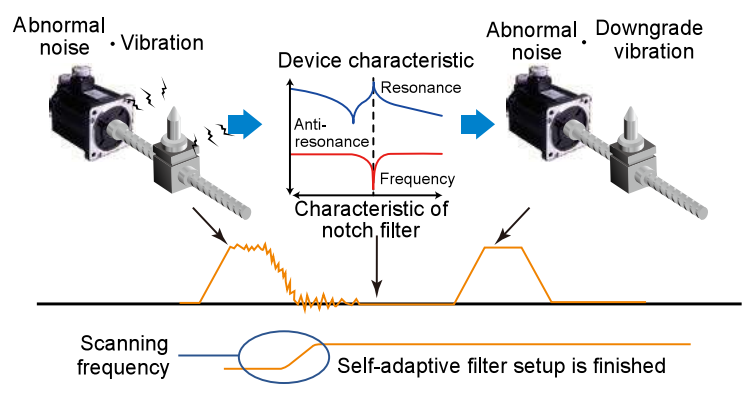

Low frequency vibration control

Special low frequency vibration control algorithm can be used to effectively overcome low frequency mechanical resonance and control the oscillation of long swing arm end.

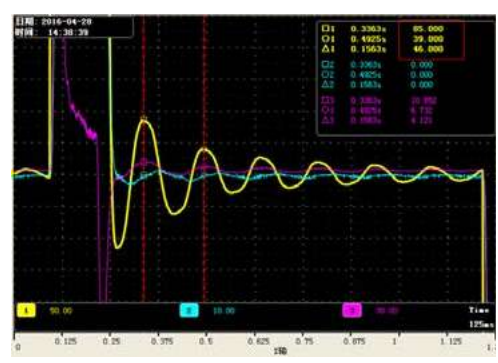

No vibration control

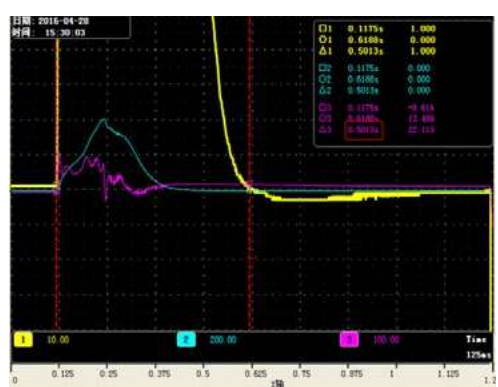

Vibration control

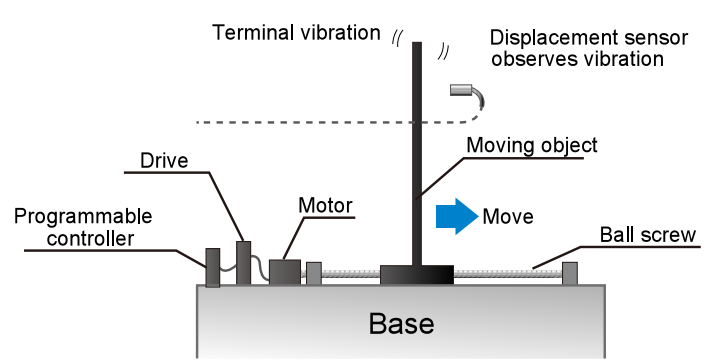

■ Gantry synchronism

Support dual shaft alignment and dual shaft synchronous tracking. The controller conducts synchronous control automatically without the need for complicated upper PC control. When position deviation exceeds the set value, alarm will be reported to stop system operation.

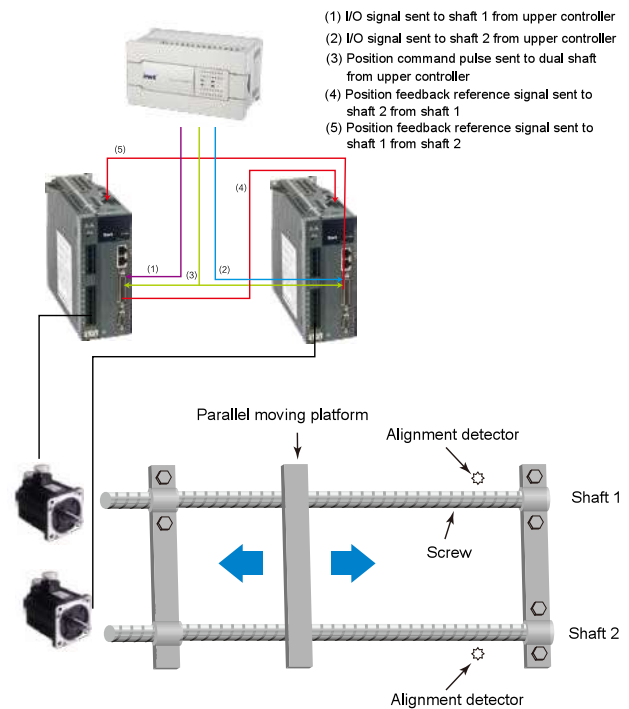
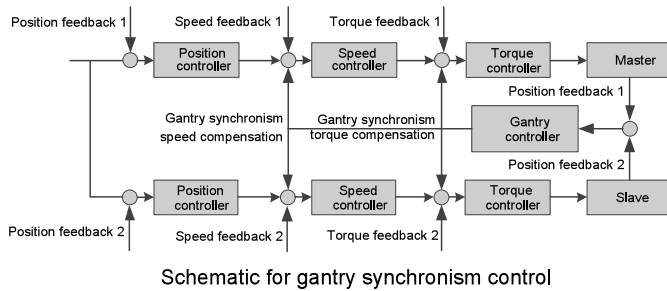

■ Disturbance control

Equipped with disturbance control function to compensate for the impact on control performance made by load disturbance and parameter change, thus enhancing system robustness and greatly improving tracking performance of the command.

■ Friction torque compensation

Equipped with friction torque compensation function to downgrade the impact made by static friction during motor commutation and improve command tracking performance in low speed.

■ Simple gain adjustment and switching

Adjust speed loop, position loop gain and filter time constant automatically via rigidity level setting to effectively reduce the complicity of commissioning; Support two groups of gain setting, and gain switching can be realized by IO input, communication or internal variables, fulfilling flexible demands in the process.

■ Speed observer

Adopt speed observer to effectively reduce the impact made by noise signal and improve command tracking performance.

Humanized operation software

- Convenient and user-friendly operation interface
- Multiple functions and easy to use
- Practicle instruction manual for commissioning

Channel	Func Select	Active Mode	Communication Con...	Communication State	State Feedback
Type: Digital Input					
Digital Input1	0x03:Servo on	<input checked="" type="radio"/> High <input type="radio"/> Low	<input checked="" type="radio"/> Enable <input type="radio"/> Disable	<input type="checkbox"/> Invalid	<input type="checkbox"/> Invalid
Digital Input2	0x0D:Zero speed ...	<input type="radio"/> High <input checked="" type="radio"/> Low	<input type="radio"/> Enable <input checked="" type="radio"/> Disable	<input type="checkbox"/> Invalid	<input type="checkbox"/> Invalid
Digital Input3	0x04:Fault recover	<input type="radio"/> High <input checked="" type="radio"/> Low	<input type="radio"/> Enable <input checked="" type="radio"/> Disable	<input type="checkbox"/> Invalid	<input type="checkbox"/> Invalid
Digital Input4	0x16:Emergency	<input type="radio"/> High <input checked="" type="radio"/> Low	<input type="radio"/> Enable <input checked="" type="radio"/> Disable	<input type="checkbox"/> Invalid	<input type="checkbox"/> Invalid
Digital Input5	0x19:Electronic g...	<input type="radio"/> High <input checked="" type="radio"/> Low	<input type="radio"/> Enable <input checked="" type="radio"/> Disable	<input type="checkbox"/> Invalid	<input type="checkbox"/> Invalid
Digital Input6	0x1A:Electronic g...	<input type="radio"/> High <input checked="" type="radio"/> Low	<input type="radio"/> Enable <input checked="" type="radio"/> Disable	<input type="checkbox"/> Invalid	<input type="checkbox"/> Invalid
Digital Input7	0x01:POT	<input type="radio"/> High <input checked="" type="radio"/> Low	<input type="radio"/> Enable <input checked="" type="radio"/> Disable	<input type="checkbox"/> Invalid	<input type="checkbox"/> Invalid
Digital Input8	0x02:NOT	<input type="radio"/> High <input checked="" type="radio"/> Low	<input type="radio"/> Enable <input checked="" type="radio"/> Disable	<input type="checkbox"/> Invalid	<input type="checkbox"/> Invalid
Digital Input9	0x07:Position erro...	<input type="radio"/> High <input checked="" type="radio"/> Low	<input type="radio"/> Enable <input checked="" type="radio"/> Disable	<input type="checkbox"/> Invalid	<input type="checkbox"/> Invalid
Digital Input10	0x08:Pulse input ...	<input type="radio"/> High <input checked="" type="radio"/> Low	<input type="radio"/> Enable <input checked="" type="radio"/> Disable	<input type="checkbox"/> Invalid	<input type="checkbox"/> Invalid
Type: Digital Output					
Digital Output1	0x01:Servo ready	<input type="radio"/> High <input checked="" type="radio"/> Low	<input type="radio"/> Enable <input checked="" type="radio"/> Disable	<input type="checkbox"/> Invalid	<input checked="" type="checkbox"/> Valid
Digital Output2	0x03:Fault output	<input type="radio"/> High <input checked="" type="radio"/> Low	<input type="radio"/> Enable <input checked="" type="radio"/> Disable	<input type="checkbox"/> Invalid	<input type="checkbox"/> Invalid
Digital Output3	0x07:In position	<input type="radio"/> High <input checked="" type="radio"/> Low	<input type="radio"/> Enable <input checked="" type="radio"/> Disable	<input type="checkbox"/> Invalid	<input type="checkbox"/> Invalid
Digital Output4	0x0D:Speed zero	<input type="radio"/> High <input checked="" type="radio"/> Low	<input type="radio"/> Enable <input checked="" type="radio"/> Disable	<input type="checkbox"/> Invalid	<input checked="" type="checkbox"/> Valid
Digital Output5	0x05:Brake off	<input type="radio"/> High <input checked="" type="radio"/> Low	<input type="radio"/> Enable <input checked="" type="radio"/> Disable	<input type="checkbox"/> Invalid	<input type="checkbox"/> Invalid
Digital Output6	0x0E:Torque limit...	<input type="radio"/> High <input checked="" type="radio"/> Low	<input type="radio"/> Enable <input checked="" type="radio"/> Disable	<input type="checkbox"/> Invalid	<input type="checkbox"/> Invalid

Digital I/O can directly select effective terminal logic and function distribution

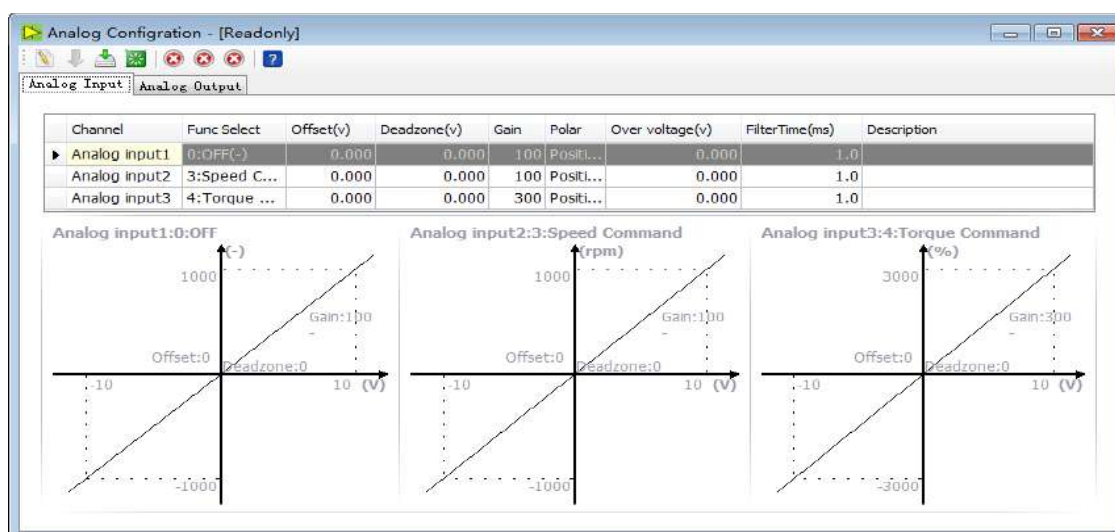

Analog I/O can set gain, zero offset and deadzone parameters as shown above

Alarm information - [Error Un-Clear]

Current Error: Error Record 1

Error Code	Name	Value	Unit
Error Record: 1			
2-0 : Encoder fault - disconnect	Power on time	0/0/22/9:5:42	s
	Run time	0/0/4/10:15:32	s
	Speed feedback of motor	0.0	r/min
	Speed command of motor	0.0	r/min
	Position feedback accumulation	0	pulse
	Position command accumulation	0	pulse
	Position error	0	pulse
	Torque feedback	0.0	%
	DC bus voltage	320.9	V
	Output voltage	0.0	Vrms
	Output current	0.00	Arms
Error Record: 2			
Error Record: 3			

Display fault info. in real time and read fault record info.

Bulk Operate

Group	Func Code	Name	Type	Read Va...	Actual Value	Resolution	Min	Max	Unit	Description
P0	P0.56	Acceleration S...	int16	0	0	0	0	1000	ms	
P0	P0.57	Deceleration ...	int16	0	0	0	0	1000	ms	
P0	P0.58	Zero speed cl...	int16	0	0	0	0	3	-	
P0	P0.59	Zero speed cl...	int16	30	30	0	10	20000	r/min	
P0	P0.60	Torque comm...	int16	BUS input 2	0	0	0	3	-	
P0	P0.61	Torque comm...	int16	T-SIGN...	0	0	0	1	-	
P0	P0.62	Gain of Analo...	int32	100	100	0	0	2000	0.1...	
P0	P0.63	Polarity of An...	int16	Positive	0	0	0	1	-	
P0	P0.65	Dead zone of ...	int16	0.000	0	3	0	3	V	
P0	P0.66	Internal torqu...	int16	0.0	0	1	-500	500	%	
P0	P0.67	Speed limitab...	int16	Internal...	1	0	0	1	-	
P0	P0.68	Torque comm...	int16	0	0	0	0	10000	ms	
P0	P0.69	Quick stop time	int16	500	500	0	0	10000	ms	
P0	P0.70	Speed limitab...	int16	Single-t...	0	0	0	1	-	
P0	P0.90	Control mode ...	int16	100	100	0	1	1000	r/min	
P0	P0.91	Control mode ...	int32	-1	-1	0	-1	8388608	pulse	
P0	P0.92	Instane...	int16	1	0	0	0	1	-	

Read finished,total62parameters,0 parameters! Operate Percentage

Bulk reading function can store parameters to files for easy parameter copying

Application Control

Program JOG

Parameter setting

Mode select

FS.00[Mode select] 0 (Range0-5)

Time and cut

FS.03[secs/decc] 100 n= (Range0-10000)

Speed setting

FS.01[Move set] 50000 pulse (Range1-1073741024)

FS.04[Stop wait time] 100 n= (Range0-10000)

FS.02[Speed set] 500 r/min (Range0-5000)

FS.05[Run times] 1 (Range0-10000)

Software restrict

FS.36[Negative resc] 0 (Range-2147483647 to 2147483647)

FS.35[Positive resc] 0 (Range-2147483647 to 2147483647)

< Previous Next > Cancel

Abundant application control function for convenient pilot run and commissioning

Application cases

Mechanical arm/Robot

Function overview:

- Simple servo commissioning
- Fit with any articulated robot controller

Function description:

- Automatic gain adjustment to quickly optimize servo performance of each joint .
- INVT servo drive system to ensure flexible and accurate robot actions
- The repeated positioning precision is up to $\pm 0.01\text{mm}$.



High speed drilling center

Function overview:

- Fast response speed
- Strong overload capacity, high positioning precision

Function description:

- Excellent performance in low speed heavy cut, thread processing, rigid tapping, etc; equipped with spindle high speed positioning and multi-step speed drilling positioning function.
- The speed response of DA200 can be up to 2.0kHz with 23-bit high precision encoder and tripled overload capacity.



Lithium cell winding

Function overview:

- EtherCAT field bus
- DA200 ECAM

Function description:

- High speed real time EtherCAT field bus to replace the original pulse mode, achieving high precision servo control and high reliability of the device.
- Built-in DA200 ECAM function to easily realize variable/constant speed winding; quick type change via one key without the need for setting any winding needle dimension parameter.
- Integrated internal unwinding and rectification program to greatly improve action response.



LED sorting machine

Function overview:



- DA200 with 23-bit absolute encoder
- High rigidity, high speed, high response and high precision

Function description:

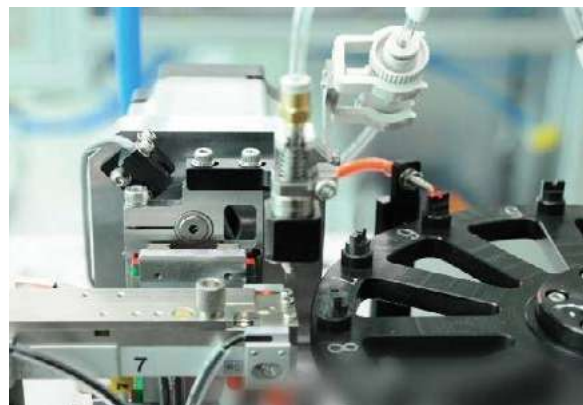
- Utilize the excellent response performance of DA200 to pull up motor frequency width and optimize the overall device operation.
- DA200 carries 23-bit absolute encoder and advanced algorithm to realize high rigidity, high speed, high response and high precision positioning control and fulfill application needs during stable low speed operation.
- INVT DA200 has reached 70k/h, the highest industry standard currently.



Servo drive configuration table

1PH/3PH 220V									
Servo drive									
	SIZE A			SIZE B			SIZE D		
Servo motor	SV-DA200-0R1-2	SV-DA200-0R2-2	SV-DA200-0R4-2	SV-DA200-0R7-2	SV-DA200-1R0-2	SV-DA200-1R5-2	SV-DA200-2R0-2	SV-DA200-3R0-2	SV-DA200-4R4-2
	SV-ML04-0R1G-2	SV-ML06-0R2G-2	SV-ML06-0R4G-2	SV-ML08-0R7G-2	SV-MH13-0R8B-2	SV-MH13-1R3B-2	SV-MM11-1R8G-2	SV-MM13-3R0E-2	SV-MM18-4R4B-2
				SV-MH08-0R7G-2	SV-MM11-0R8E-2	SV-MM11-1R2E-2	SV-MM13-2R0E-2	SV-MM18-3R0B-2	
					SV-MM13-1R0E-2	SV-MM11-1R2G-2			
						SV-MM11-1R5G-2			
					SV-MM13-1R5E-2				

3PH 400V						
Servo drive						
	SIZE B		SIZE C		SIZE D	
Servo motor	SV-DA200-1R0-4	SV-DA200-1R5-4	SV-DA200-2R0-4	SV-DA200-3R0-4	SV-DA200-4R4-4	SV-DA200-5R5-4
	SV-MH13-0R8B-4	SV-MH13-1R3B-4	SV-MM11-1R8G-4	SV-MM13-3R0E-4	SV-MM18-4R4B-4	SV-MM18-5R5B-4
	SV-MM11-0R8E-4	SV-MM11-1R2E-4	SV-MM13-2R0E-4	SV-MM18-3R0B-4		
	SV-MM13-1R0E-4	SV-MM11-1R2G-4				
		SV-MM11-1R5G-4				
	SV-MM13-1R5E-4					
Servo drive						
	SIZE F		SIZE F2		SIZE G	
Servo motor	SV-DA200-7R5-4	SV-DA200-011-4	SV-DA200-015-4	SV-DA200-022-4		
	SV-MM18-7R5B-4	SV-MH20-011B-4	SV-MH20-015B-4	SV-SH26-022B-4		
	SV-SM18-7R5B-4					

/ Servo drive model instruction

SV-DA200-0R4-2-E 0-XXXX

① ② ③ ④ ⑤ ⑥ ⑦

①

Symbol	Product category
SV	Servo system product

④

Symbol	Rated voltage
2	220VAC
4	400VAC

②

Symbol	Product category
DA200	Servo drive

⑤

Symbol	Drive type
E	Pulse type
S	Standard type
C	CANopen bus type
P	PROFIBUS-DP bus type
N	EtherCAT bus type
M	Motionnet bus type
K	Customized

③

Symbol	Rated power
0R1	100W
0R2	200W
0R4	400W
0R7	750W
1R0	1.0kW
1R5	1.5kW
2R0	2.0kW
3R0	3.0kW
4R4	4.4kW
5R5	5.5kW
7R5	7.5kW
011	11kW
015	15kW
022	22kW

⑥

Symbol	Encoder type
0	Photoelectric encoder (2500-wire incremental, 17-bit single/multi-turn absolute, 23-bit multi-turn absolute)
7	Rotary transformer

⑦

Symbol	Lot no.
XXXX	Manufacturer lot no.

Function differentiation of differing machine type (small power range: 100W~5.5kW)

Drive type	Symbol	Pulse input	16 bit analog	Second encoder	STO	RS485	CANopen	PROFIBUS-DP	EtherCAT	Motionnet	2500-wire, 17/23 bit photoelectric encoder	Rotary trans.
Pulse	E	√	X	√	X	√	X	X	X	X	√	√
Standard	S	√	√	√	√	√	X	X	X	X	√	√
Bus	C	X	X	√	X	X	√	X	X	X	√	X
	P	X	X	√	X	X	X	√	X	X	√	X
	N	X	X	√	X	X	X	X	√	X	√	X
	M	X	X	√	X	√	X	X	X	√	√	X
Customized	K	√	X	√	X	√	√	X	X	X	√	√

Function differentiation of differing machine type (medium power range: 7.5kW~22kW)

Drive type	Symbol	Pulse input	16 bit analog	Second encoder	STO	RS485	CANopen	PROFIBUS-DP	EtherCAT	Motionnet	2500-wire, 17/23 bit photoelectric encoder	Rotary trans.
Standard	S	√	√	√	√	√	√	X	X	X	√	√
Bus	N	X	X	√	√	X	X	X	√	X	√	√
Customized	K	√	X	√	√	√	√	X	X	X	√	√

Power and chassis classification of drive series

Model	Input	Output		Chassis volume
	Voltage (V)	Power (kW)	Rated current (A)	
SV-DA200-0R1-2	1PH/3PH 220	0.1	1.3	A
SV-DA200-0R2-2	1PH/3PH 220	0.2	1.8	A
SV-DA200-0R4-2	1PH/3PH 220	0.4	2.8	A
SV-DA200-0R7-2	1PH/3PH 220	0.75	4.5	B
SV-DA200-1R0-2	1PH/3PH 220	1.0	5	B
SV-DA200-1R5-2	3PH 220	1.5	7.6	B
SV-DA200-2R0-2	3PH 220	2.0	10	D
SV-DA200-3R0-2	3PH 220	3.0	13	D
SV-DA200-4R4-2	3PH 220	4.4	16.5	D
SV-DA200-1R0-4	3PH 400	1.0	3.5	B
SV-DA200-1R5-4	3PH 400	1.5	4.5	B
SV-DA200-2R0-4	3PH 400	2.0	6.5	C
SV-DA200-3R0-4	3PH 400	3.0	8.5	C
SV-DA200-4R4-4	3PH 400	4.4	12	D
SV-DA200-5R5-4	3PH 400	5.5	16	D
SV-DA200-7R5-4	3PH 400	7.5	25	F
SV-DA200-011-4	3PH 400	11.0	33	F
SV-DA200-015-4	3PH 400	15.0	50	F2
SV-DA200-022-4	3PH 400	22.0	66	G

Drive dimension

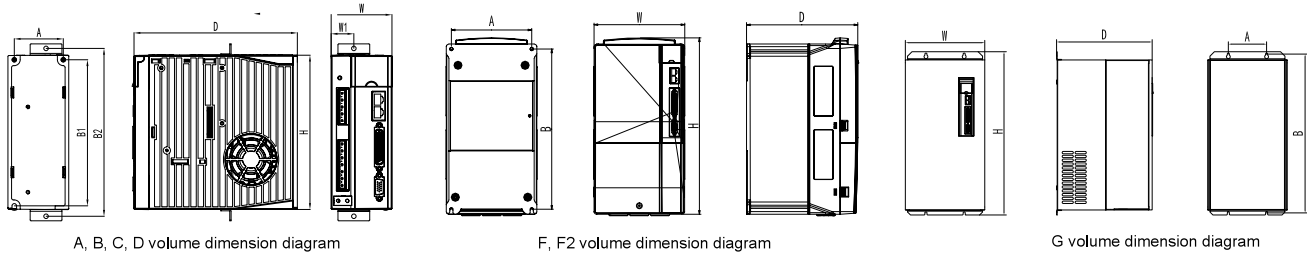

A, B, C, D volume dimension diagram

F, F2 volume dimension diagram

G volume dimension diagram

Brake resistor specification

Vol.	Model	Outline dimension			Installation dimension				Installation bore (mm)
		H (mm)	W (mm)	D (mm)	A (mm)	B1 (mm)	B2 (mm)	W1 (mm)	
A	SV-DA200-0R1-2	170	45	170	33	162	185	22.5	M4(Φ5)
	SV-DA200-0R2-2								
	SV-DA200-0R4-2								
B	SV-DA200-0R7-2	170	67	180	54	162	185	25	M4(Φ5)
	SV-DA200-1R0-2								
	SV-DA200-1R5-2								
D	SV-DA200-2R0-2	245	92	190	79	237	260	45	M4(Φ5)
	SV-DA200-3R0-2								
	SV-DA200-4R4-2								
B	SV-DA200-1R0-4	170	67	180	54	162	185	25	M4(Φ5)
	SV-DA200-1R5-4								
C	SV-DA200-2R0-4	170	84	180	71	162	185	42	M4(Φ5)
	SV-DA200-3R0-4								
D	SV-DA200-4R4-4	245	92	190	79	237	260	45	M4(Φ5)
	SV-DA200-5R5-4								
F	SV-DA200-7R5-4	342	230	208	210	311	/	/	M5(Φ6)
	SV-DA200-011-4								
F2	SV-DA200-015-4	407	255	238	237	384	/	/	M6(Φ7)
G	SV-DA200-022-4	555	270	325	130	540	/	/	M6(Φ7)

Model	Built-in brake resistor spec.	Min. allowed resistance of external brake resistor
SV-DA200-0R1-2	/	60 Ω
SV-DA200-0R2-2	/	60 Ω
SV-DA200-0R4-2	/	60 Ω
SV-DA200-0R7-2	30 Ω 60W	30 Ω
SV-DA200-1R0-2	30 Ω 60W	30 Ω
SV-DA200-1R5-2	30 Ω 60W	20 Ω
SV-DA200-2R0-2	15 Ω 120W	15 Ω
SV-DA200-3R0-2	15 Ω 120W	15 Ω
SV-DA200-4R4-2	15 Ω 120W	15 Ω
SV-DA200-1R0-4	60 Ω 60W	60 Ω
SV-DA200-1R5-4	60 Ω 60W	60 Ω
SV-DA200-2R0-4	60 Ω 60W	40 Ω
SV-DA200-3R0-4	60 Ω 60W	30 Ω
SV-DA200-4R4-4	30 Ω 120W	30 Ω
SV-DA200-5R5-4	30 Ω 120W	30 Ω
SV-DA200-7R5-4	/	30 Ω
SV-DA200-011-4	/	20 Ω
SV-DA200-015-4	/	15 Ω
SV-DA200-022-4	/	10 Ω

Technical parameters of servo drive

DA200 series servo drive (0.1kW~22kW)					
Specification		Instruction			
Power	220V system input voltage	1P/3P AC 220V(-15%)~240V(+10%) 47Hz~63Hz			
	400V system input voltage	3P AC 380V(-15%)~440V(+10%) 47Hz~63Hz			
Port	Control signal	Input	General 10 inputs, EtherCAT bus servo 7 inputs, Motionnet servo 5 inputs (function can be set via relevant parameters)		
		Output	General 6 inputs, EtherCAT bus servo 4 inputs, Motionnet servo 1 input (function can be set via relevant parameters)		
	Analog	Input	Standard 3 inputs (one 16bit, two 12bit analog inputs) other two-channel inputs (two 12bit analog inputs)		
		Output	2 outputs (analog monitoring output)		
	Pulse signal	Input	2 inputs, differential input or open collector input		
		Output	6 outputs, 3 differential outputs, 3 open collector outputs		
	Second encoder	Input	Incremental encoder interface (second encoder or full closed-loop grating ruler)		
	Communication	USB	1:1 communication upper PC software (standard)		
		RS485	1:n communication (standard)		
		CANopen	1:n communication (optional)		
		PROFIBUS-DP	1:n communication (optional)		
		EtherCAT	1:n communication (optional)		
	Safety terminal	STO	Safe Torque Off (comply with latest Euro safety standard) (optional)		
Control mode	1. Position control; 2. Speed control; 3. Torque control; 4. Position/speed mode switching; 5. Speed/torque mode switching; 6. Position/torque mode switching; 7. Full closed-loop control; 8. CANopen mode; 9. EtherCAT mode; 10. Motionnet mode				
Function	Position control	Control input	1. Retaining pulse clearance; 2. Command pulse input disabled; 3. Command frequency division/doubling switching; 4. Vibration control switching		
		Control output	Position complete output		
		Pulse input	Max. pulse input frq.	Photoelectric coupling: differential input 4Mpps, open collector input 200kpps	
			Pulse input mode	1. Positive/negative direction; 2. A phase/B phase; 3. Command pulse/command direction	
			Electronic gear	1/10000~1000	
			Filter	1. Command smooth filter; 2. FIR filter	
		Analog input	Torque limit	Can perform clockwise/anticlockwise torque limit separately	
		Vibration control	Can control 5~200Hz front-end vibration and machine vibration		
Pulse output	1. Can perform any frequency division setting which is below encoder resolution rate; 2. B phase reversing function				

DA200 series servo drive (0.1kW~22kW)					
Specification		Instruction			
Function	Speed control	Control input	1. Internal command speed selection 1; 2. Internal command speed selection 2; 3. Internal command speed selection 3; 4. Zero speed clamp		
		Control output	Speed arrival		
		Analog input	Speed command input	Can set to speed command input based on analog voltage DC±10V	
			Torque limit input	Can carry out torque limit clockwise/anticlockwise separately	
		Internal speed command	Can switch between internal 8-step speed based on external input control		
		Speed command acc/dec adjustment	Can set acc/dec time separately or set acc/dec of S curve		
		Zero speed clamp	In speed mode, zero speed clamp function can set to work in speed mode or position mode		
		Speed command filter	First-order delay filter of analog input speed command		
	Speed command zero drift control	Can carry out zero drift control against peripheral disturbance, precision 0.3mV			
	Torque control	Control input	Zero speed clamp input		
		Control output	Speed arrival		
		Analog input	Torque command input	Analog torque command input, can set gain and polarity based on analog voltage, precision 4.88mV	
			Speed limit input	Can carry out analog speed limit	
		Speed limit	Speed limit can be set via parameters		
		Torque command filter	First-order delay filter of analog input torque command		
		Torque command zero drift control	Can carry out zero drift control against peripheral disturbance, precision is 4.88mV		
	Internal position planning	Plan points	Can carry out 128-point internal position plan setting, support communication control positioning		
		Route setting	1. Position; 2. Speed; 3. Acc time; 4. Dec time; 5. Stop timer; 6. Various state output; 7. Running mode		
Homing		1. LS signal; 2. Z phase signal; 3. LS signal+Z phase signal; 4. Torque limit signal			
Protection	Hardware protection	Overvoltage, undervoltage, overcurrent, overspeed, overload, overheat, brake resistor overload, encoder fault, etc.			
	Software protection	Storage fault, initialization fault, I/O distribution error, position deviation is too large, etc.			
	Protection and fault record	1. Can record up to 10 faults 2. Can record the key parameter value when fault occurred			
Environment	Temperature	Working temp	0~45°C		
		Storage temp	-20~80°C (Non frozen)		
	Humidity	Working/storage: ≤ 90%RH (no condensation)			
	IP level	IP20			
	Altitude	Below 1000m			
	Vibration	≤5.88m/s ² , 10~60Hz (Do not work on resonance point)			

Servo motor model instruction

Naming rules

SV-M M 13-3R0 E-4-1 A 0-XXXX

① ② ③ ④ ⑤ ⑥ ⑦ ⑧ ⑨ ⑩ ⑪

①

Symbol	Product category
SV	Servo system

②

Symbol	Product category
M	M series
C	C series
S	S series

③

Symbol	Inertia level
L	Small inertia
M	Medium inertia
H	Large inertia

④

Symbol	Base no.
04	40 ⁽³⁾
06	60
08	80
11	110
13	130
18	180
20	200
26	263

⑤

Symbol	Rated power
0R1	100W
0R2	200W
0R4	400W
0R7	750W
0R8	800W/850W
1R0	1.0kW
1R2	1.2kW
1R3	1.3kW
1R5	1.5kW
1R8	1.8kW
2R0	2.0kW
3R0	3.0kW
4R4	4.4kW
5R5	5.5kW
7R5	7.5kW
011	11kW
015	15kW
022	22kW
...	...

⑥

Symbol	Rated speed
A	1000rpm
B	1500rpm
E	2000rpm
F	2500rpm
G	3000rpm

⑦

Symbol	Voltage class
2	220VAC
4	380VAC

⑧

Symbol	Encoder type
1	2500-wire standard incremental
2	2500-wire multiplexed incremental ⁽¹⁾
3	17-bit single-turn absolute ⁽²⁾
4	17-bit multi-turn absolute
7	Rotary transformer
9	23-bit multi-turn absolute

⑨

Symbol	Shaft end connection
A	Solid threaded with key (Standard)
B	Solid optical axis

⑩

Symbol	Optional parts
0	With oil seal but no brake
1	W/o oil seal or brake ⁽¹⁾
2	With oil seal and permanent magnet brake
3	W/o oil seal but with permanent magnet brake ⁽¹⁾
4	With oil seal and electromagnetic brake
5	W/o oil seal but with electromagnetic brake ⁽¹⁾

⑪

Symbol	Lot no.
XXXX	Manufacturer's product lot no. ⁽⁴⁾

Remark:

(1): Special model, the lead time will be longer than usual.

(2): 17-bit single-turn absolute value encoder belongs to a separate series with different dimensions and parameters, only electromagnet brake is used. Please pay attention to corresponding series when selecting models.

(3): 40-base motor, support 2500-wire and 17-bit absolute value encoder only.

(4): No need to fill in when selecting models for the first time.

In addition: Non 17-bit single-turn absolute 40/60-base motor supports permanent magnet brake only.

Technical parameters of servo motor

Motor specification (2500-wire/multi-turn absolute/rotary transformer)

Motor model (2500-wire/multi-turn absolute/ rotary transformer)	Rated power (kW)	Rated current (A)	Max. momentary current (A)	Rated torque (Nm)	Max. momentary torque (Nm)	Rated speed (rpm)	Max. speed (rpm)	Rotation inertia standard/with brake (kg.cm ²)	Voltage (V)	Weight standard/with brake (kg)
ML series small inertia										
SV-ML04-0R1G-2-□□□	0.1	0.6	1.2	0.32	0.64	3000	6000	0.051/0.055	220	0.47/0.67
SV-ML06-0R2G-2-□□□	0.2	1.2	3.6	0.64	1.91			0.175/0.22		1.16/1.66
SV-ML06-0R4G-2-□□□	0.4	2.8	8.4	1.27	3.9			0.29/0.33		1.6/2.1
SV-ML08-0R7G-2-□□□	0.75	4.5	13.5	2.39	7.2			1.28/1.51		3.0/3.5
MM/SM series medium inertia										
SV-MM11-0R8E-2-□□□	0.8	3.5	10.5	4	12	2000	3000	5.4/6.7	220	6/7.7
SV-MM11-1R2E-2-□□□	1.2	4.5	13.5	6	18			7.6/8.9		7.9/9.6
SV-MM11-1R2G-2-□□□	1.2	5	15	4	12	3000	4000	5.4/6.7	220	6/7.7
SV-MM11-1R5G-2-□□□	1.5	6	18	5	15			6.3/7.6		6.8/8.5
SV-MM11-1R8G-2-□□□	1.8	6	18	6	18	2000	3000	7.6/8.9	220	7.9/9.6
SV-MM13-1R0E-2-□□□	1	4.8	14.4	4.78	14.3			6.4/8.3		5.8/7.5
SV-MM13-1R5E-2-□□□	1.5	7.6	22.8	7.16	21.4	2000	3000	9.3/11.2	380	7.1/8.8
SV-MM13-2R0E-2-□□□	2	9.5	28.5	9.55	28.6			12.2/14.1		8.4/10.1
SV-MM13-3R0E-2-□□□	3	13.6	40.8	14.3	42	2000	3000	18/19.9	380	10.8/12.5
SV-MM13-1R0E-4-□□□	1	2.8	8.4	4.78	14.3			6.4/8.3		5.8/7.5
SV-MM13-1R5E-4-□□□	1.5	4.5	13.5	7.16	21.4	2000	3000	9.3/11.2	380	7.1/8.8
SV-MM13-2R0E-4-□□□	2	5.5	16.5	9.55	28.6			12.2/14.1		8.4/10.1
SV-MM13-3R0E-4-□□□	3	7.8	23.4	14.3	42	1500	2000	18/19.9	220	10.8/12.5
SV-MM18-3R0B-2-□□□	3	12	29.7	19	47			70/74		20.5/25
SV-MM18-4R4B-2-□□□	4.4	16	39.7	27	67	1500	2000	97/101	220	25.5/30
SV-MM18-3R0B-4-□□□	3z	7.5	18.7	19	47			70/74		20.5/25
SV-MM18-4R4B-4-□□□	4.4	10	25	27	67	1500	2000	97/101	380	25.5/30
SV-MM18-5R5B-4-□□□	5.5	12	24	35	70			86/127		30.5/35.7
SV-MM18-7R5B-4-□□□	7.5	20	40	48	96	1500	3000	168/179	380	40/46.5
SV-SM18-7R5B-4-□□□	7.5	24	62	48	120			190/201		46/52.5
MH/SH series large inertia										
SV-MH06-0R4G-2-□□□	0.4	2.8	8.4	1.27	3.81	3000	6000	0.67/0.77	220	2.0/2.2
SV-MH08-0R7G-2-□□□	0.75	4.5	13.5	2.39	7.2			2.5/2.73		3.3/3.8
SV-MH13-0R8B-2-□□□	0.85	5.5	16.5	5.41	16.2	1500	2000	13.4/15.4	220	6.6/8.3
SV-MH13-1R3B-2-□□□	1.3	8.2	24.6	8.34	25			23.4/25.4		9.3/11
SV-MH13-0R8B-4-□□□	0.85	3.2	9.6	5.41	16.2	1500	2000	13.4/15.4	380	6.6/8.3
SV-MH13-1R3B-4-□□□	1.3	4.8	14.4	8.34	25			23.4/25.4		9.3/11
SV-MH20-011B-4-□□□	11	22.7	69	70	175	1500	2000	98.3/106.3	380	49/66
SV-MH20-015B-4-□□□	15	42.5	107	95.5	240			119/127		56/73
SV-SH26-022B-4-□□□	22	61	153	140	350	1500	2000	390/412	380	103/133
Insulation grade	Class F (155°C)									
Protection grade	IP65									
Ambient environment	Temp: -20°C~+40°C (Non-frozen) ; RH: Below 90% (No condensation)									

Motor specification (17-bit single-turn absolute)

Motor model (17-bit single-turn absolute)	Rated power (kW)	Rated current (A)	Max. momentary current (A)	Rated torque (Nm)	Max. momentary torque (Nm)	Rated speed (rpm)	Max. speed (rpm)	Rotation inertia standard/with brake (kg.cm ²)	Voltage (V)	Weight standard/with brake (kg)
ML series small inertia										
SV-ML04-0R1G-2-3A□	0.1	1.1	3.3	0.32	0.96	3000	6000	0.036/0.037	220	0.47/0.67
SV-ML06-0R2G-2-3A□	0.2	1.2	3.6	0.64	1.92	3000	5000	0.176/0.179		1.01/1.4
SV-ML06-0R4G-2-3A□	0.4	2.3	6.9	1.27	3.81			0.3/0.302		1.37/1.78
SV-ML08-0R7G-2-3A□	0.75	4.3	12.9	2.5	7.5			1.015/1.018		2.5/3.4
MM series medium inertia										
SV-MM13-1R0E-2-3A□	1	4.72	14.2	4.77	14.3	2000	3000	8.71/8.72	220	6.41/7.94
SV-MM13-1R5E-2-3A□	1.5	6.87	20.6	7.16	21.5			12.08/12.1		7.9/9.4
SV-MM13-2R0E-2-3A□	2	9.18	27.5	9.55	28.6			17.14/17.16		10.12/11.67
SV-MM13-3R0E-2-3A□	3	12.95	38.85	14.3	42.9			25.58/25.59		13.8/15.4
SV-MM13-1R0E-4-3A□	1	2.5	7.5	4.77	14.3			8.71/8.72	380	6.41/7.94
SV-MM13-1R5E-4-3A□	1.5	4.1	12.3	7.16	21.5			12.08/12.1		7.9/9.4
SV-MM13-2R0E-4-3A□	2	6.5	19.5	9.55	28.6			17.14/17.16		10.12/11.67
SV-MM13-3R0E-4-3A□	3	9.6	28.8	14.3	42.9			25.58/25.59		13.8/15.4
Insulation grade	Class F (155°C)									
Protection grade	IP65									
Ambient environment	Temp: -20°C~+40°C (Non-frozen) ; RH: Below 90% (No condensation)									

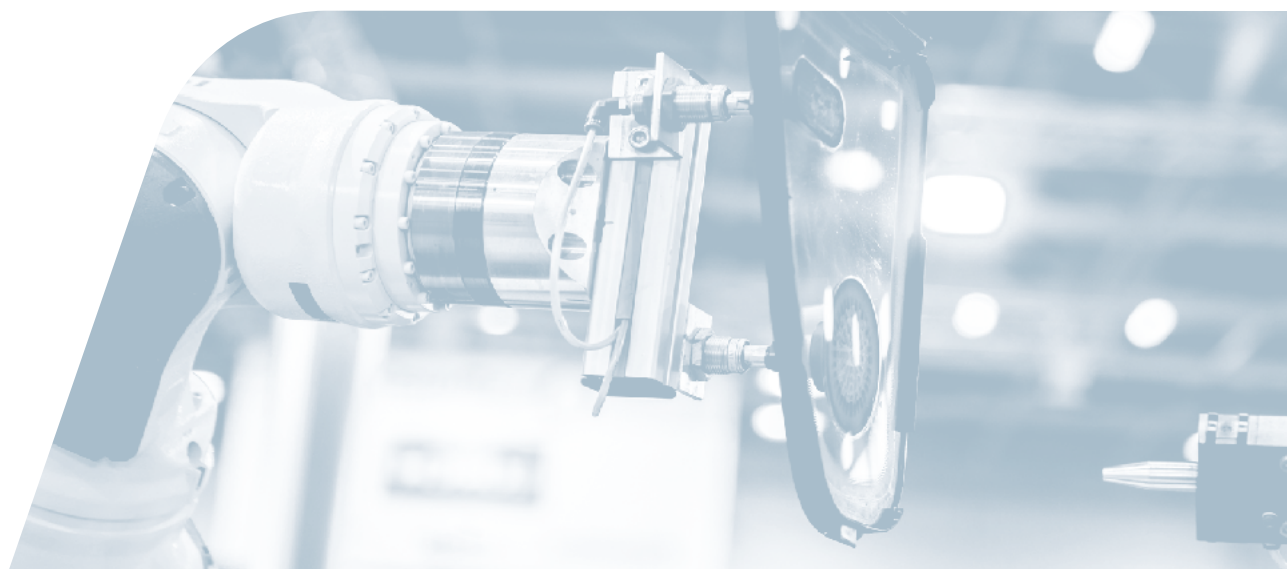

Servo motor installation dimension

Note: Motor structure dimension may change with design modification. For customers who require exact length, Please confirm with our business staff before ordering.

40-base motor outline dimension (unit: mm)

Motor model (2500-wire/multi-turn absolute)	L(mm)	
	No brake	Permanent magnet brake
SV-ML04-0R1G-2-□A□	90	124

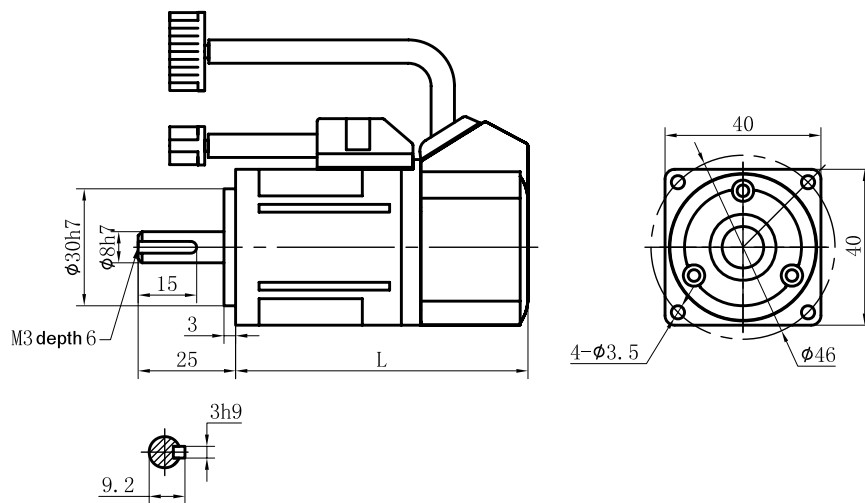

Motor model (17-bit single-turn encoder)	L(mm)	
	No brake	Electro-magnet brake
SV-ML04-0R1G-2-3A□	90.3	123

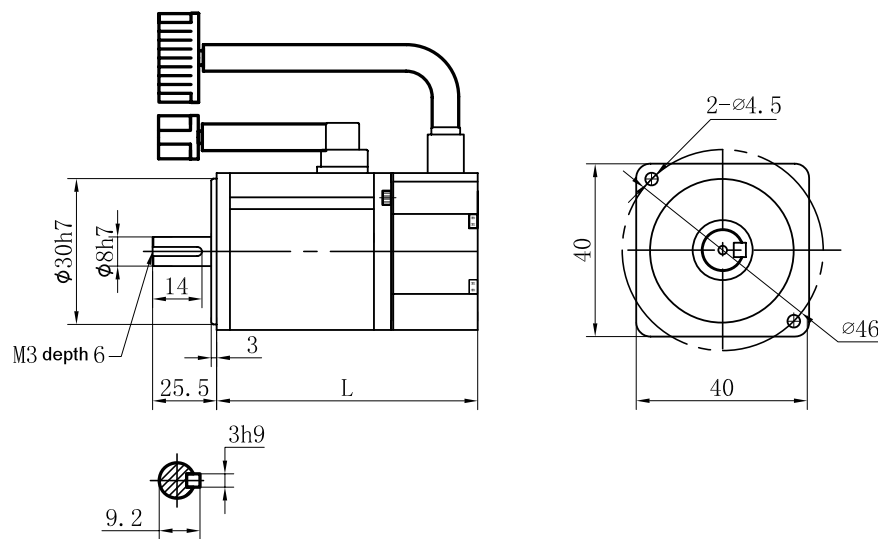

60-base motor outline dimension (unit: mm)

Motor model (2500-wire/multi-turn absolute/ rotary transformer)	L(mm)	
	No brake	Permanent magnet brake
SV-ML06-0R2G-2-□A□	116	164
SV-ML06-0R4G-2-□A□	141	189
SV-MH06-0R4G-2-□A□	147	191

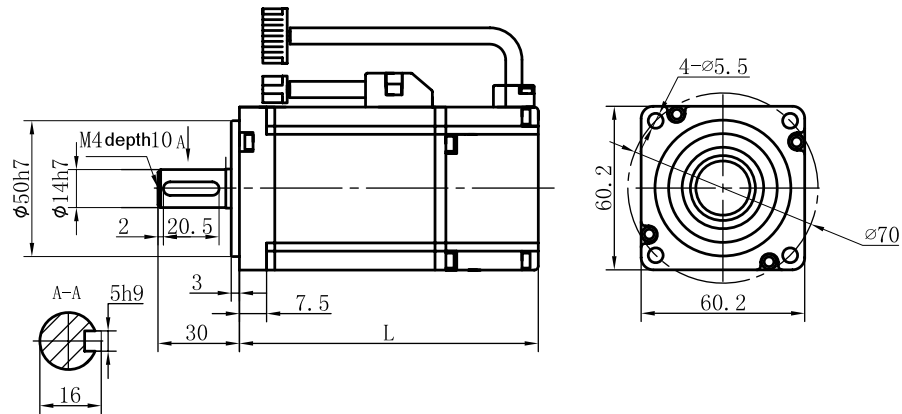

Motor model (17-bit single-turn encoder)	L(mm)	
	No brake	Electro-magnet brake
SV-ML06-0R2G-2-3A□	114	147
SV-ML06-0R4G-2-3A□	133	167

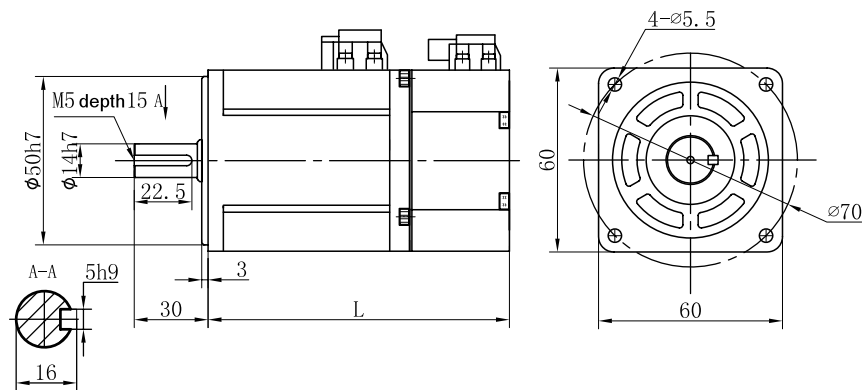

80-base motor outline dimension (unit: mm)

Motor model (2500-wire/multi-turn absolute/ rotary transformer)	L(mm)		
	No brake	Permanent magnet brake	Electro-magnet brake
SV-ML08-0R7G-2-□A□	140	186	186
SV-MH08-0R7G-2-□A□	151	205	205

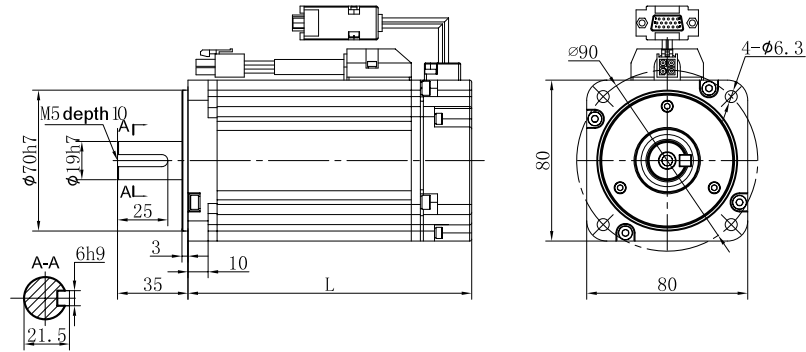

Motor model (17-bit single-turn encoder)	L(mm)	
	No brake	Electro-magnet brake
SV-ML08-0R7G-2-3A□	141	173

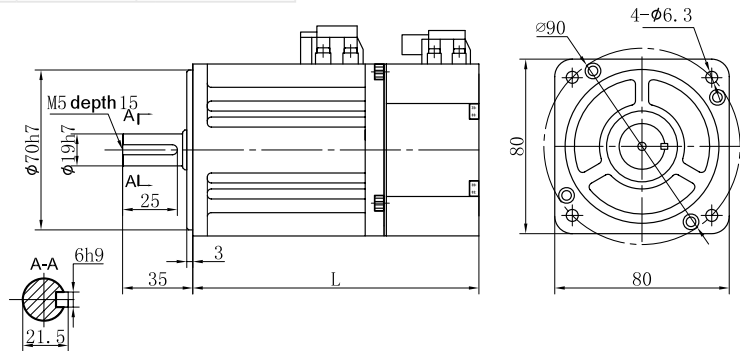

110-base motor outline dimension (unit: mm)

Motor model (2500-wire/multi-turn absolute/ rotary transformer)	L(mm)		
	No brake	Permanent magnet brake	Electro-magnet brake
SV-MM11-0R8E-2-□A□	189	245	263
SV-MM11-1R2G-2-□A□			
SV-MM11-1R5G-2-□A□	204	260	278
SV-MM11-1R2E-2-□A□			
SV-MM11-1R8G-2-□A□	219	275	293

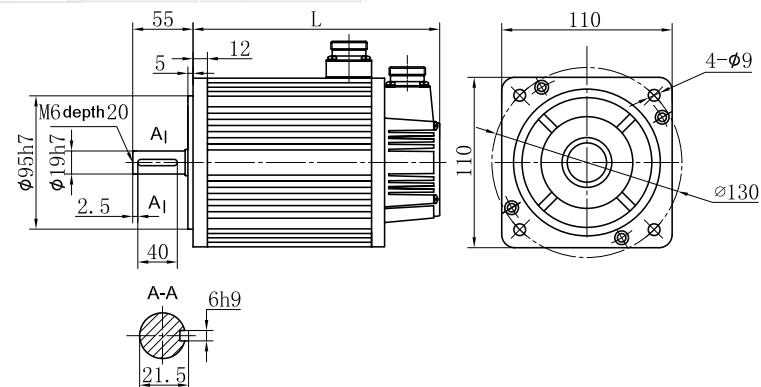

130-base motor outline dimension (unit: mm)

Motor model (2500-wire/multi-turn absolute/ rotary transformer)	L(mm)		
	No brake	Permanent magnet brake	Electro-magnet brake
SV-MM13-1R0E-□-□A□	143	185	185
SV-MM13-1R5E-□-□A□	159	201	201
SV-MM13-2R0E-□-□A□	175	217	217
SV-MM13-3R0E-□-□A□	207	249	249
SV-MH13-0R8B-□-□A□	167	209	209
SV-MH13-1R3B-□-□A□	202	244	244

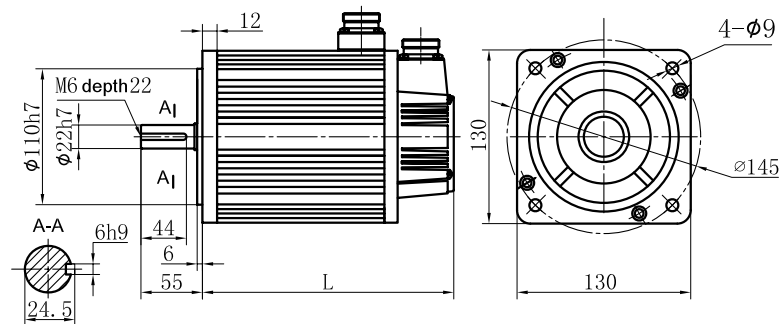

Motor model (17-bit single-turn encoder)	L(mm)	
	No brake	Electro-magnet brake
SV-MM13-1R0E-□-3A□	165	220
SV-MM13-1R5E-□-3A□	185	240
SV-MM13-2R0E-□-3A□	215	270
SV-MM13-3R0E-□-3A□	265	320

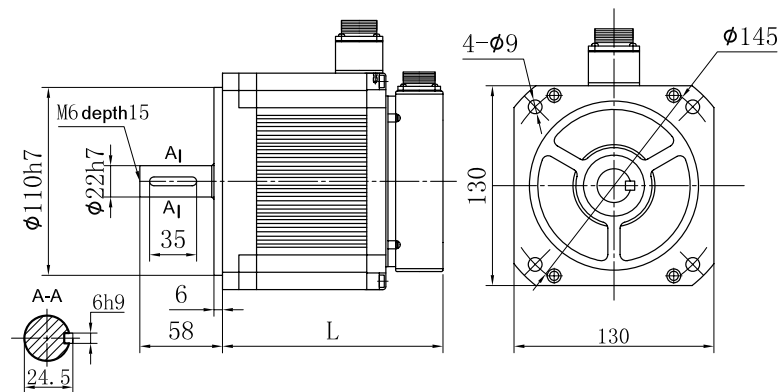

200-base motor outline dimension (unit: mm)

Motor model (2500-wire/multi-turn absolute/ rotary transformer)	L(mm)		
	No brake	Permanent magnet brake	Electro-magnet brake
SV-MH20-011B-4-□A□	411	547	547
SV-MH20-015B-4-□A□	446	582	582

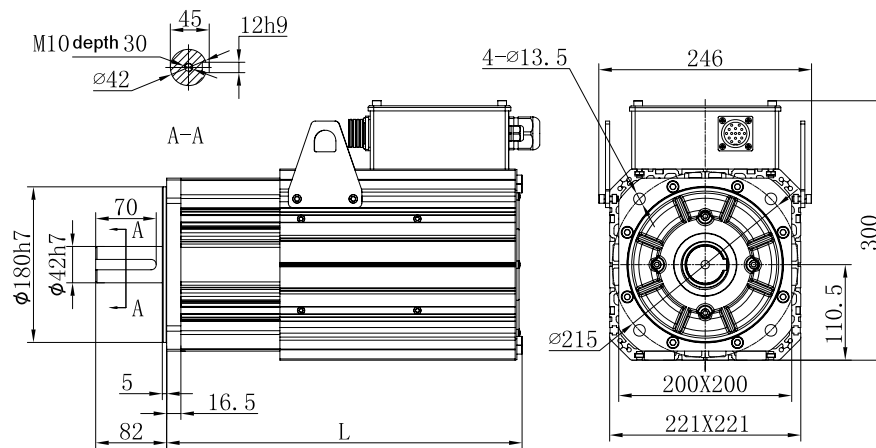

263-base motor outline dimension (unit: mm)

Motor model (2500-wire/multi-turn absolute/ rotary transformer)	L(mm)
	No brake
SV-SH26-022B-4-□A□	537

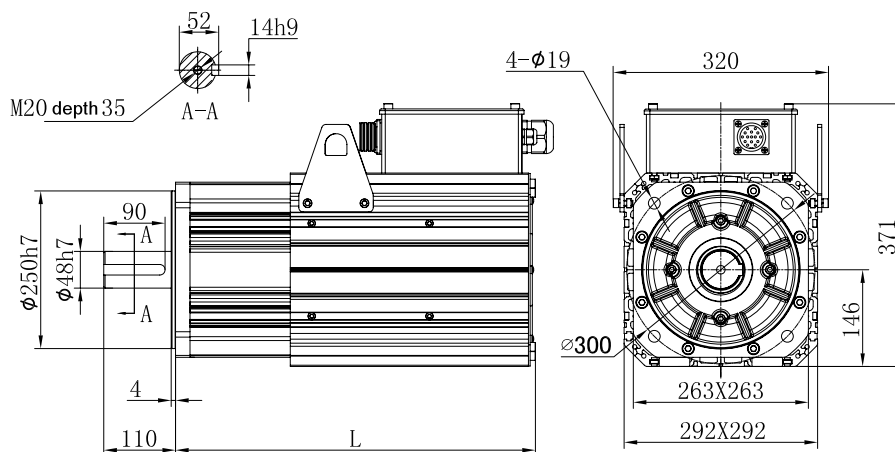

Servo motor torque-speed characteristic

Note: A (continuous working area) B (short-time working area)

40-base motor

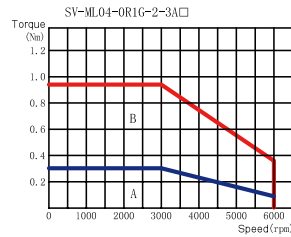
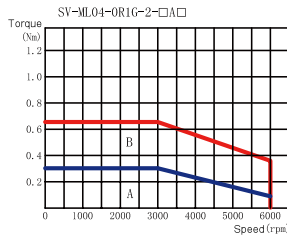

60-base motor

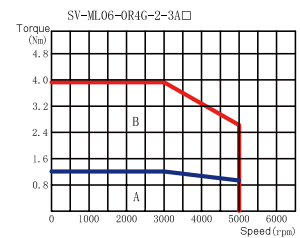
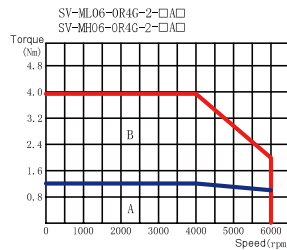
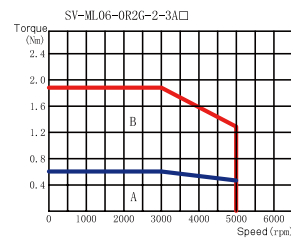
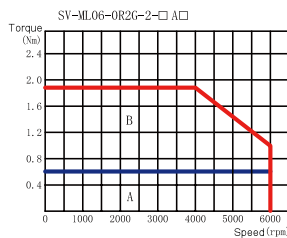

80-base motor

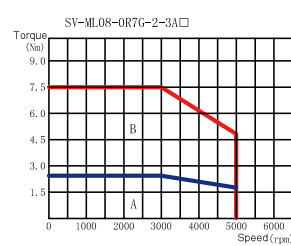
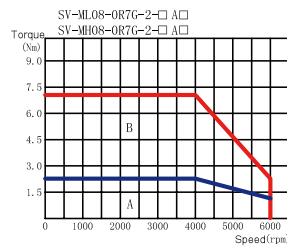

110-base motor

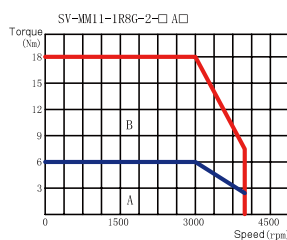
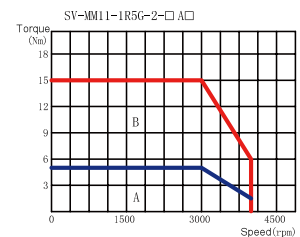
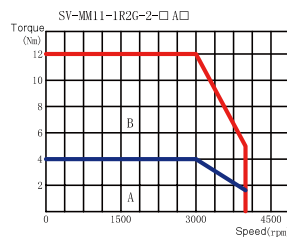
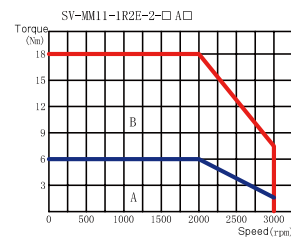
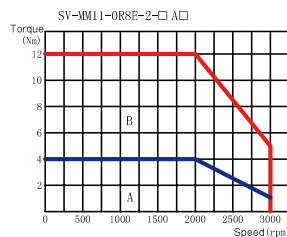

130-base motor

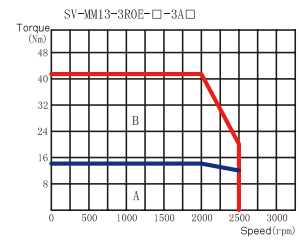
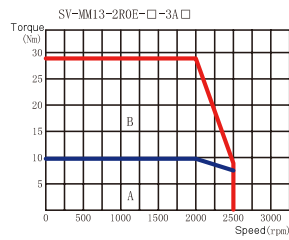
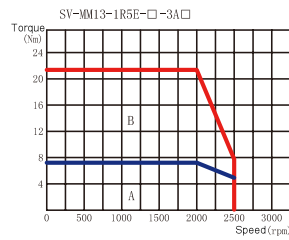
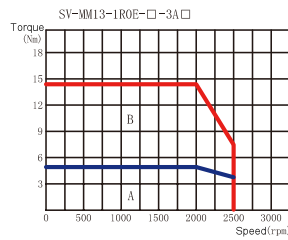
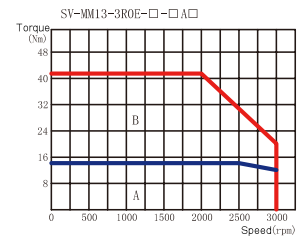
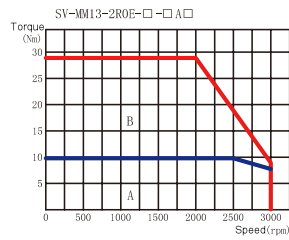
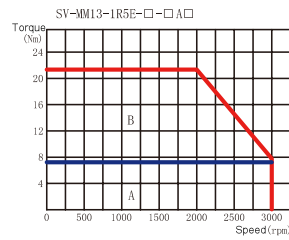
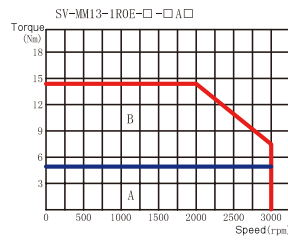

180-base motor

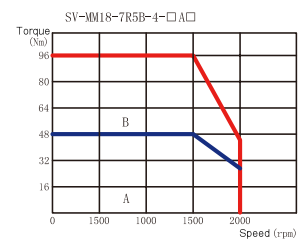
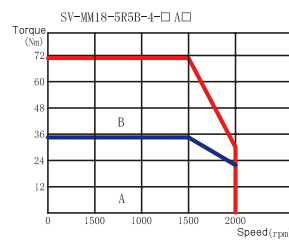
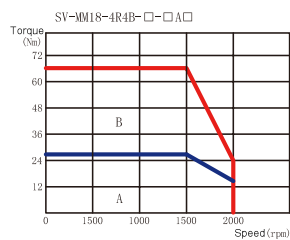
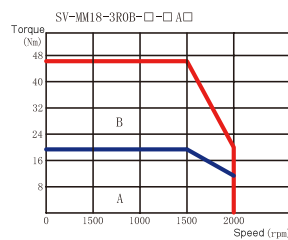
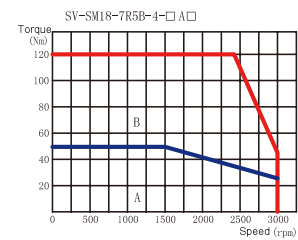
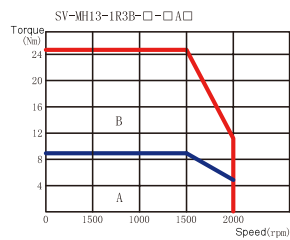
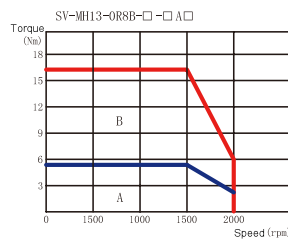

200/263-base motor

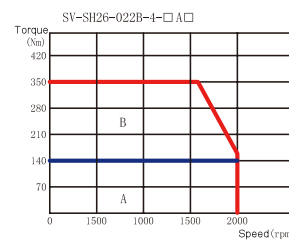
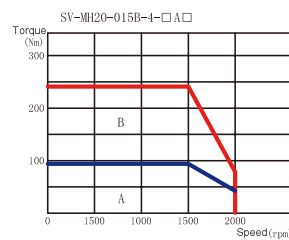
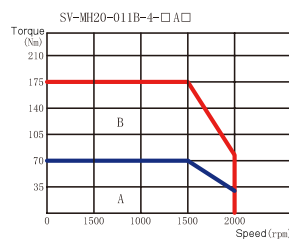

Servo motor power cable model

Power cable

DA ML-075-05-A A F-00

① ② ③ ④ ⑤ ⑥ ⑦ ⑧

Power cable accessories

DA ML-A A

① ② ⑤ ⑥

①

Symbol	Supporting series
DA	Manufacturer no.

②

Symbol	Cable type
ML	Power cable

③

Symbol	Cable diameter
075	0.75mm ²
100	1.0mm ²
150	1.5mm ²
250	2.5mm ²
400	4.0mm ²
10R	10.0mm ²

④

Symbol	Cable length
03	3m
05	5m
10	10m
20	20m

⑤

Symbol	Motor end plug
A	4PIN plastic plug
B	4PIN regular aviation plug YD28
C	4PIN metal plug
E	Regular aviation plug YD18
N	Regular aviation plug YD32
S	Copper tube terminal SC

⑥

Symbol	Drive end plug
B	Euro 7PIN 20A plug
W	W/o plug
S	Copper tube terminal SC

⑦

Symbol	Cable material
0	Regular cable
F	Flexible towline cable

⑧

Symbol	Lot no.
00	Standard product
01	Serial no. for non-standard product

Wiring of servo motor power cable

2500-wire 40, 60, 80-base 200W~750W motor power cable

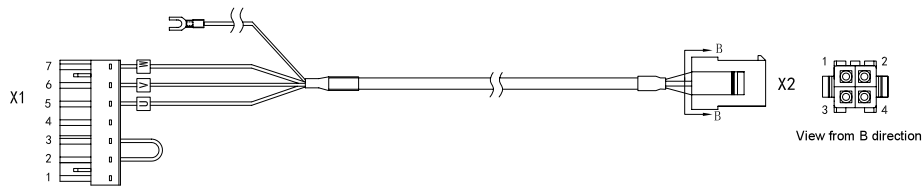

Wiring relation			
Signal	X1	X2	Color of core cable
W	X1.7	X2.3	Brown
V	X1.6	X2.1	Red
U	X1.5	X2.2	Blue
GND	GND terminal	X2.4	Yellow/green
/	X1.4	/	/
/	X1.3	Short circuit with X1.2	
/	X1.2	Short circuit with X1.3	
/	X1.1	/	/

17-bit or 23-bit 40, 60, 80-base 200W~750W motor power cable

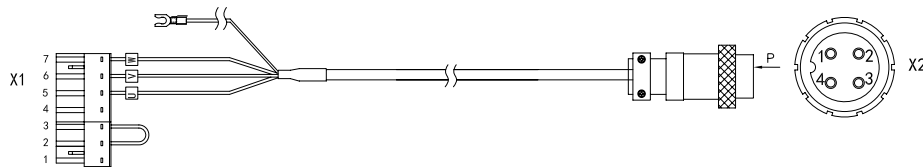

Wiring relation			
Signal	X1	X2	Color of core cable
W	X1.7	X2.1	Brown
V	X1.6	X2.3	Red
U	X1.5	X2.2	Blue
PE	GND terminal	X2.2	Yellow/green
/	X1.4	/	/
/	X1.3	Short circuit with X1.2	
/	X1.2	Short circuit with X1.3	
/	X1.1	/	/

110, 130-base 1kW~1.5kW and 2kW~3kW (380V) motor power cable

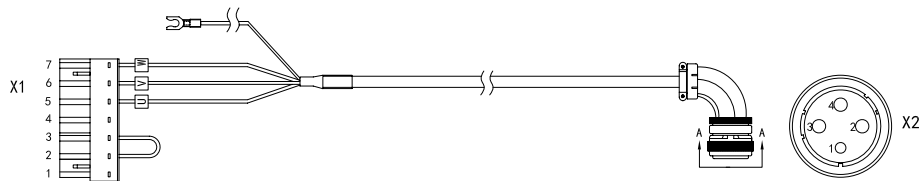

Wiring relation			
Signal	X1	X2	Color of core cable
W	X1.7	X2.4	Brown
V	X1.6	X2.3	Red
U	X1.5	X2.2	Blue
PE	GND terminal	X2.1	Yellow/green
/	X1.4	/	/
/	X1.3	Short circuit with X1.2	
/	X1.2	Short circuit with X1.3	
/	X1.1	/	/

130, 180-base 2kW~4.4kW (220V) and 4.4kW~7.5kW (380V) motor power cable

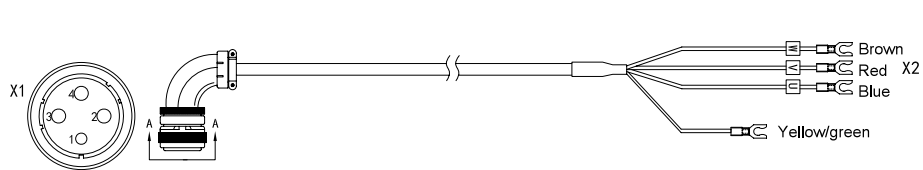

Wiring relation		
Signal	X1	Color of core cable
W	X1.4	Brown
V	X1.3	Red
U	X1.2	Blue
PE	X1.1	Yellow/green

200-base 11kW~15kW (380V) motor power cable

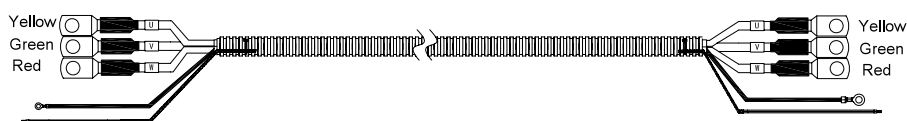

Servo motor encoder cable model

Encoder cable

DB EL-15-03-A F-01 00

① ② ③ ④ ⑤ ⑥ ⑦ ⑧

Encoder cable accessories

DB EL-A F

① ② ⑨ ⑤

①

Symbol	Supporting series
DB	Manufacturer no.

②

Symbol	Cable type
EL	Encoder cable

③

Symbol	Number of cable cores
06	6 cores
09	9 cores
15	15 cores

④

Symbol	Cable length
03	3m
05	5m
10	10m
20	20m

⑤

Symbol	Motor end plug
A	15PIN DB plug
B	15PIN regular aviation plug YD28
C	9PIN metal plug
D	6PIN plastic plug

⑥

Symbol	Cable material
0	Regular cable
D	Regular cable with battery holder
F	Flexible towline cable
H	Flexible towline cable with battery holder

⑦

Symbol	Encoder type
01	2500-wire standard incremental
04	17-bit single or multi turn/23-bit multi turn absolute value
07	Rotary transformer

⑧

Symbol	Lot no.
00	Lot no.

⑨

Symbol	Drive end plug
A	A-15PIN plastic plug

Brake cable

DRKL-03-A

① ② ③

①

Symbol	Product series
BRKL	Motor brake cable

②

Symbol	Cable length
03	3m
05	5m
10	10m
30	30m

③

Symbol	Motor end plug
A	2PIN metal plug
B	3PIN regular aviation plug
C	3PIN metal plug

Wiring of servo motor encoder cable

2500-wire 40, 60, 80-base encoder cable

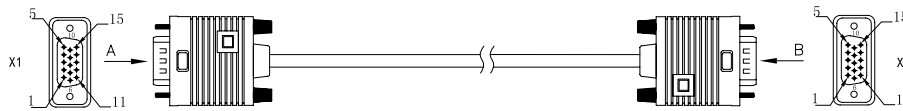

Wiring relation			
Signal	X1	X2	Core cable structure
V+	X1.1	X2.1	Twisted pair
V-	X1.7	X2.7	
W+	X1.2	X2.2	Twisted pair
W-	X1.8	X2.8	
A+	X1.3	X2.3	Twisted pair
A-	X1.4	X2.4	
U+	X1.6	X2.6	Twisted pair
U-	X1.11	X2.11	
B-	X1.9	X2.9	Twisted pair
B+	X1.10	X2.10	
Z-	X1.13	X2.13	Twisted pair
Z+	X1.14	X2.14	
5V	X1.5	X2.5	Twisted pair
GND	X1.12	X2.12	
PE	Metal shell	Metal shell	

2500-wire 110, 130, 180, 200-base encoder cable

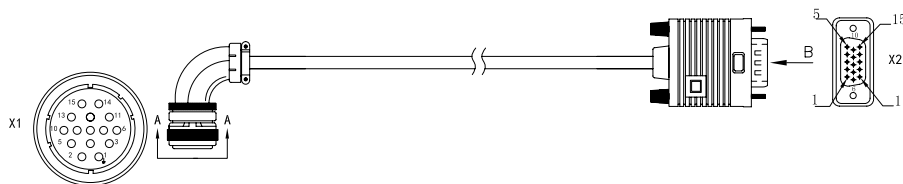

Wiring relation			
Signal	X1	X2	Core cable structure
V+	X1.11	X2.1	Twisted pair
V-	X1.14	X2.7	
W+	X1.12	X2.2	Twisted pair
W-	X1.15	X2.8	
A+	X1.7	X2.3	Twisted pair
A-	X1.4	X2.4	
U+	X1.10	X2.6	Twisted pair
U-	X1.13	X2.11	
B-	X1.8	X2.9	Twisted pair
B+	X1.5	X2.10	
Z-	X1.9	X2.13	Twisted pair
Z+	X1.6	X2.14	
5V	X1.2	X2.5	Twisted pair
GND	X1.3	X2.12	
PE	Metal shell	Metal shell	

17-bit and 23-bit 40, 60, 80-base encoder cable

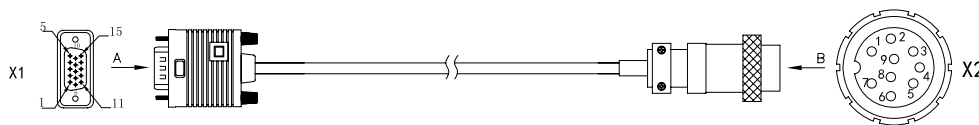

Wiring relation			
Signal	X1	X2	Core cable structure
SD+	X1.1	X2.1	Twisted pair
SD-	X1.7	X2.2	
5V	X1.5	X2.3	Twisted pair
GND	X1.12	X2.4	
VB-5V	/	X2.5	Twisted pair
VB-GND	/	X2.6	
PE	Metal shell	Metal shell	Weaving

17-bit and 23-bit 110, 130, 180, 200-base encoder cable

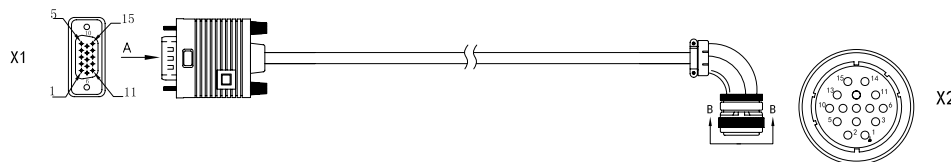

Wiring relation			
Signal	X1	X2	Core cable structure
SD+	X1.1	X2.2	Twisted pair
SD-	X1.7	X2.3	
5V	X1.5	X2.4	Twisted pair
GND	X1.12	X2.5	
VB-5V	/	X2.6	Twisted pair
VB-GND	/	X2.7	
PE	Metal shell	X2.1	Weaving

Rotary transformer type encoder cable

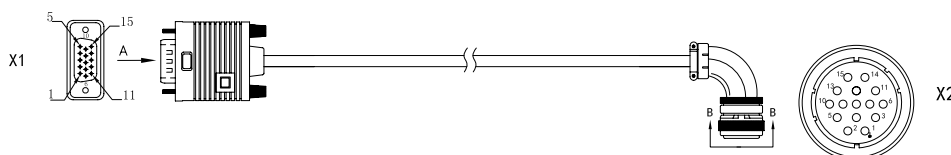

Wiring relation			
Signal	X1	X2	Core cable structure
SIN+	X1.1	X2.6	Twisted pair
SIN-	X1.7	X2.7	
COS+	X1.2	X2.5	Twisted pair
COS-	X1.8	X2.4	
R+	X1.5	X2.2	Twisted pair
R-	X1.12	X2.3	
PE	Metal shell	X2.1	Weaving

User interface

Main circuit terminal

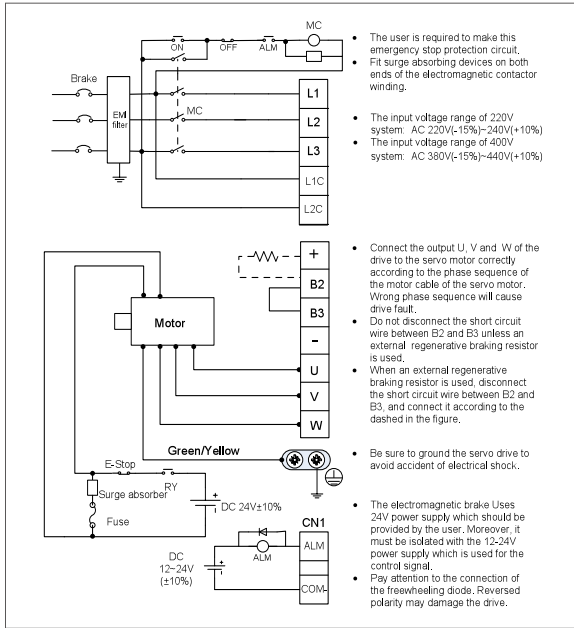

CN5 terminal

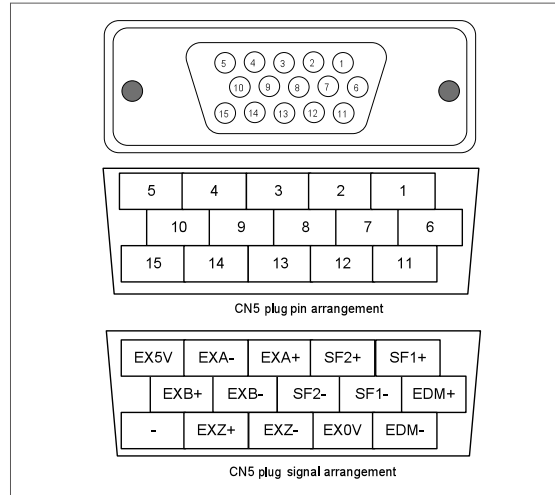

CN3 terminal

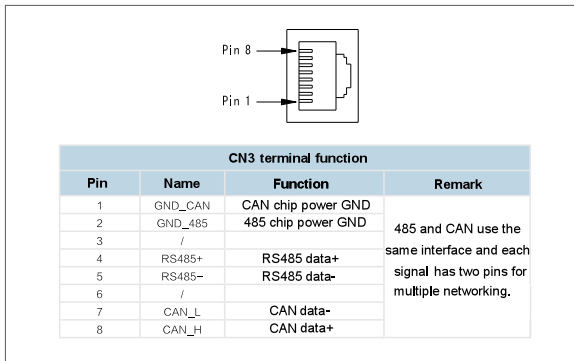

CN2 terminal

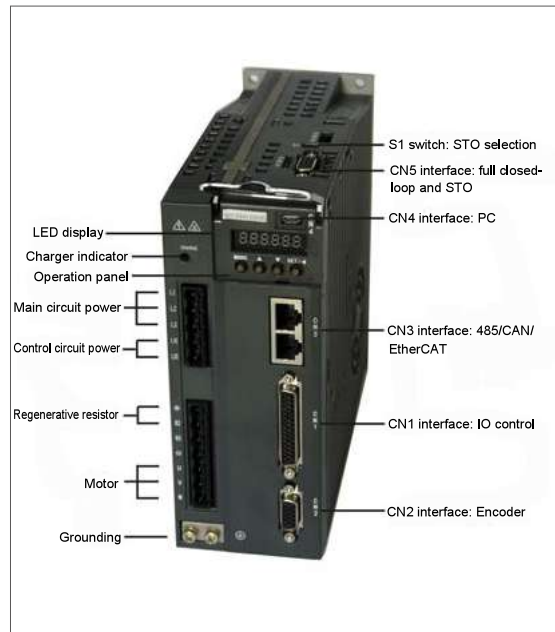
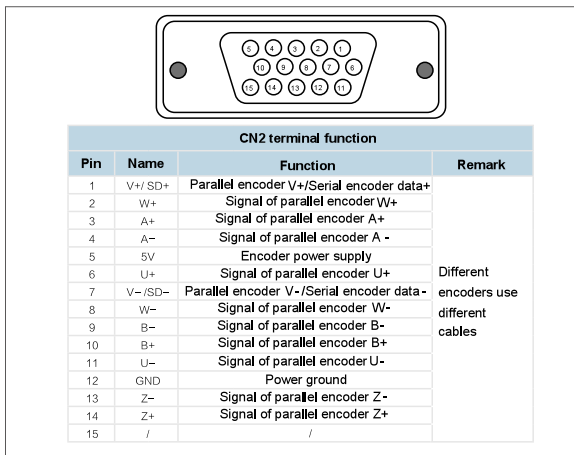

CN1 terminal

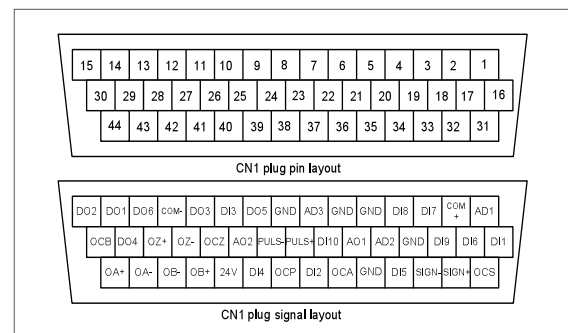

System wiring

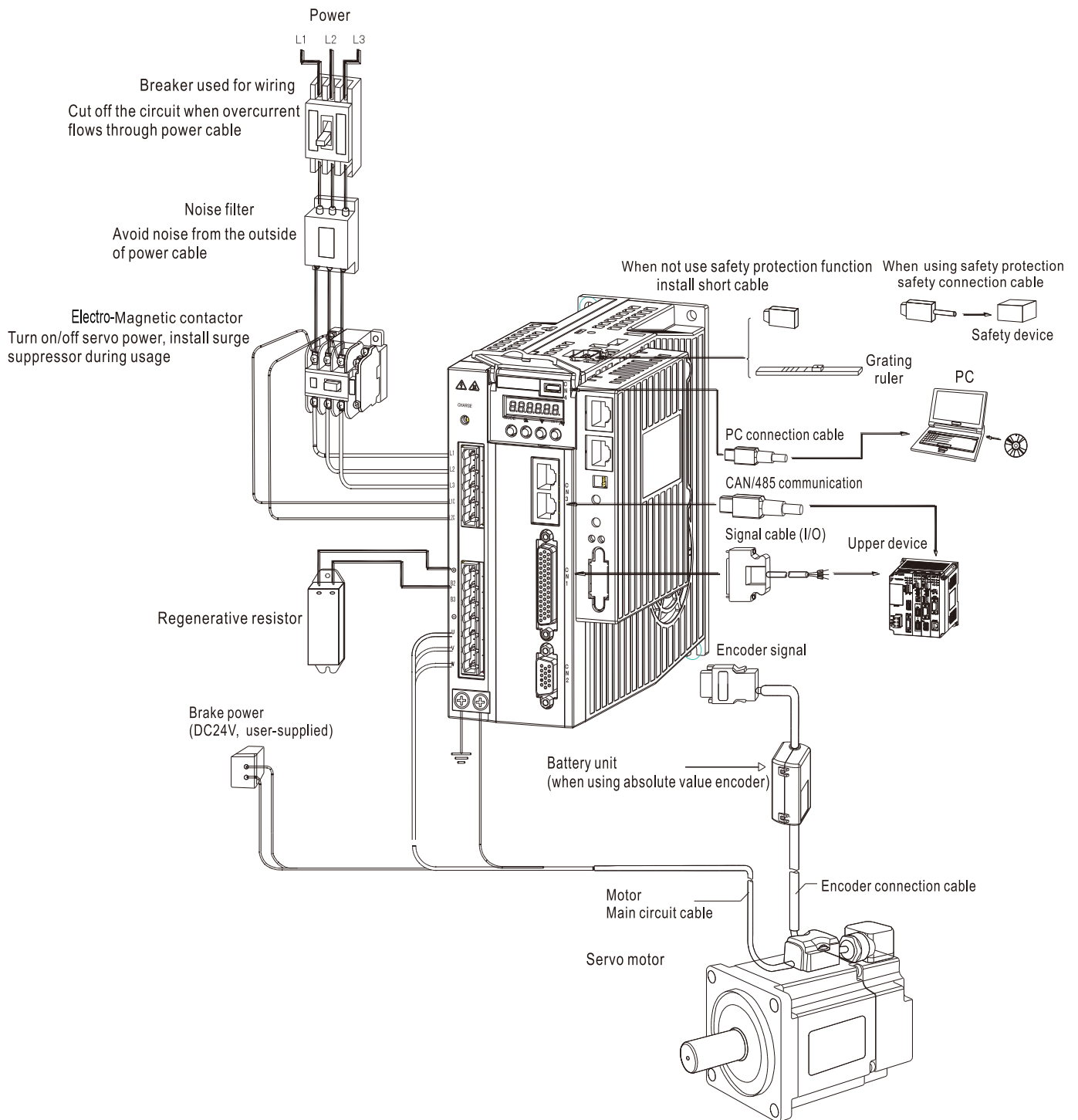

Standard wiring diagram

Speed mode wiring (suitable for analog input control)

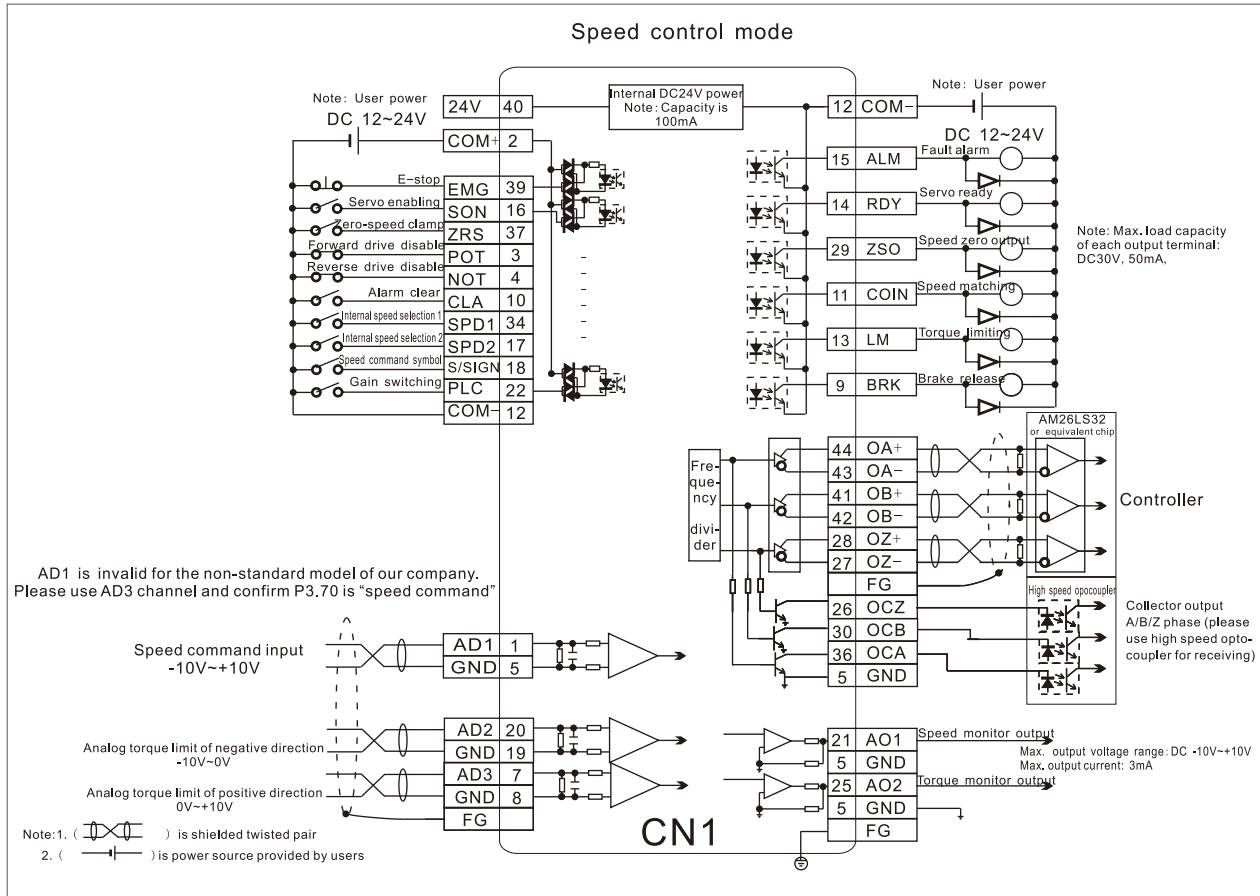

CN1 terminal

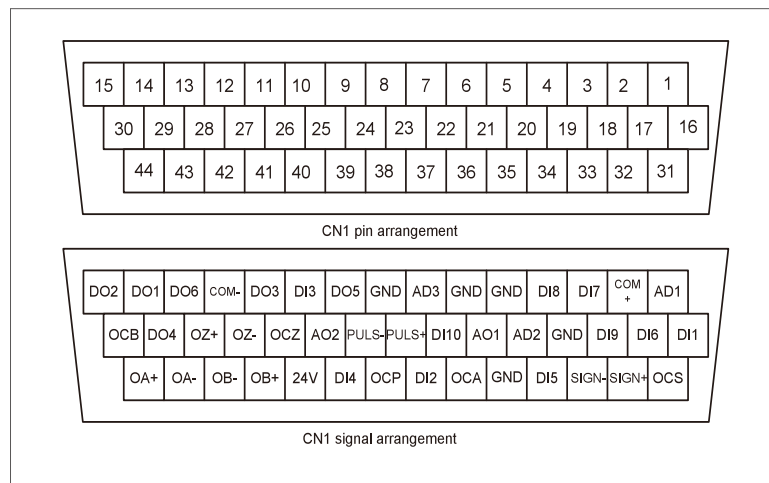

Standard wiring diagram

Position mode/full closed-loop mode wiring (suitable for pulse input control)

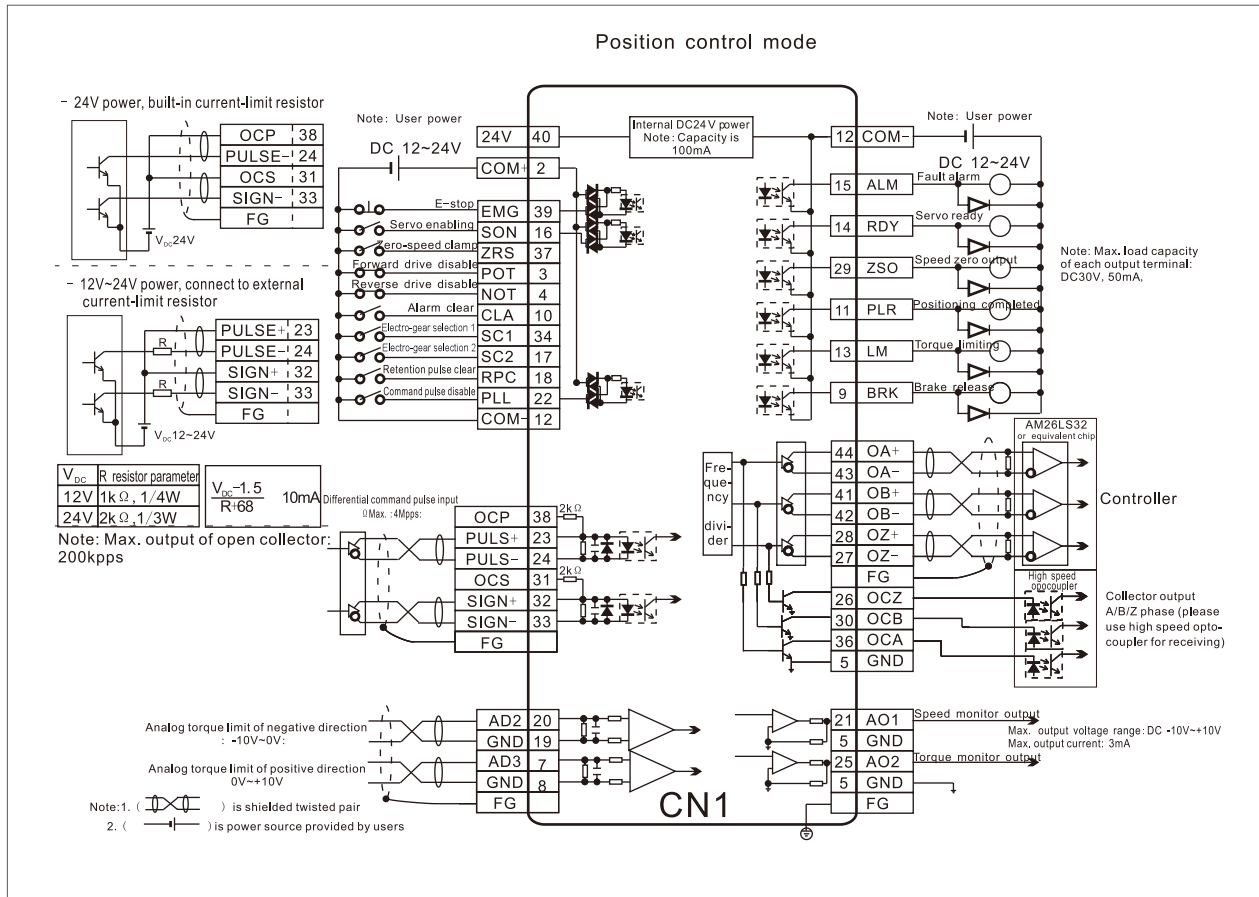

CN1 terminal

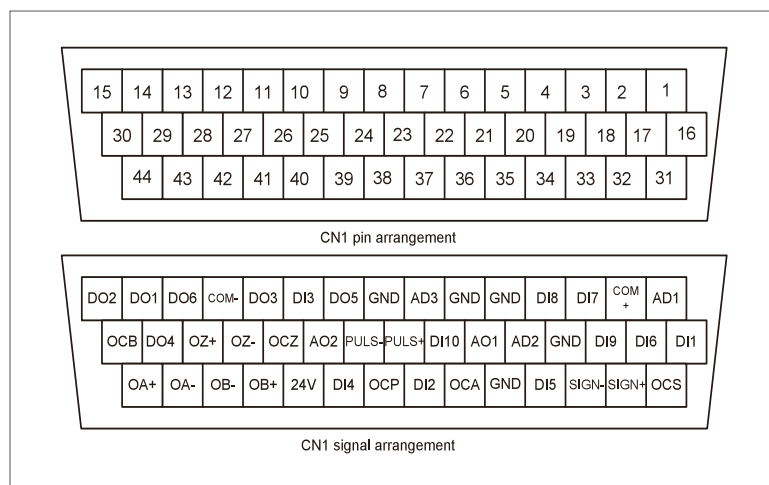

/ Servo system ordering guideline

Series	Power supply (V)	Servo motor			Servo drive			Optional parts	
		Power (kW)	Model	Rated current (A)	Model	Power (kW)	Rated current (A)	Encoder cable	Power cable
220V	220	0.1	SV-ML04-0R1G-2-XXX-XXXX	0.6	SV-DA200-0R1-2-XX-XXXX	0.1	1.3	DBEL-15-XX-A0-0000	DAML-075-XX-AB0-00
	220	0.2	SV-ML06-0R2G-2-XXX-XXXX	1.2	SV-DA200-0R2-2-XX-XXXX	0.2	1.8	DBEL-15-XX-A0-0000	DAML-075-XX-AB0-00
	220	0.4	SV-ML06-0R4G-2-XXX-XXXX	2.8	SV-DA200-0R4-2-XX-XXXX	0.4	3.3	DBEL-15-XX-A0-0000	DAML-075-XX-AB0-00
	220	0.75	SV-ML08-0R7G-2-XXX-XXXX	4.5	SV-DA200-0R7-2-XX-XXXX	0.75	4.5	DBEL-15-XX-A0-0000	DAML-075-XX-AB0-00
	220	1	SV-MM13-1R0E-2-XXX-XXXX	4.8	SV-DA200-1R0-2-XX-XXXX	1	5	DBEL-15-XX-B0-0000	DAML-150-XX-BB0-00
	220	1.5	SV-MM13-1R5E-2-XXX-XXXX	7.6	SV-DA200-1R5-2-XX-XXXX	1.5	7.6	DBEL-15-XX-B0-0000	DAML-150-XX-BB0-00
	220	2	SV-MM13-2R0E-2-XXX-XXXX	9.5	SV-DA200-2R0-2-XX-XXXX	2	10	DBEL-15-XX-B0-0000	DBML-250-XX-BW0-00
	220	3	SV-MM13-3R0E-2-XXX-XXXX	13.6	SV-DA200-3R0-2-XX-XXXX	3	13	DBEL-15-XX-B0-0000	DBML-250-XX-BW0-00
	220	4.4	SV-MM18-4R4B-2-XXX-XXXX	16	SV-DA200-4R4-2-XX-XXXX	4.4	16.5	DBEL-15-XX-B0-0000	DBML-250-XX-BW0-00
400V	400	1	SV-MM13-1R0E-4-XXX-XXXX	2.8	SV-DA200-1R0-4-XX-XXXX	1	3.5	DBEL-15-XX-B0-0000	DAML-150-XX-BB0-00
	400	1.5	SV-MM13-1R5E-4-XXX-XXXX	4.5	SV-DA200-1R5-4-XX-XXXX	1.5	4.5	DBEL-15-XX-B0-0000	DAML-150-XX-BB0-00
	400	2	SV-MM13-2R0E-4-XXX-XXXX	5.5	SV-DA200-2R0-4-XX-XXXX	2	6.5	DBEL-15-XX-B0-0000	DAML-150-XX-BB0-00
	400	3	SV-MM13-3R0E-4-XXX-XXXX	7.8	SV-DA200-3R0-4-XX-XXXX	3	8.5	DBEL-15-XX-B0-0000	DAML-150-xx-BB0-00
	400	4.4	SV-MM18-4R4B-4-XXX-XXXX	10	SV-DA200-4R4-4-XX-XXXX	4.4	12	DBEL-15-XX-B0-0000	DBML-250-XX-BW0-00
	400	5.5	SV-MM18-5R5B-4-XXX-XXXX	12	SV-DA200-5R5-4-XX-XXXX	5.5	16	DBEL-15-XX-B0-0000	DBML-250-XX-BW0-00
	400	7.5	SV-MM18-7R5B-4-XXX-XXXX	20	SV-DA200-7R5-4-XX-XXXX	7.5	25	DBEL-15-XX-B0-0000	DBML-400-XX-BW0-00
	400	11	SV-MH20-011B-4-XXX-XXXX	22.7	SV-DA200-011-4-XX-XXXX	11	33	DBEL-15-XX-B0-0000	DAML-10R-XX-SS0-00
	400	15	SV-MH20-015B-4-XXX-XXXX	42.5	SV-DA200-015-4-XX-XXXX	15	50	DBEL-15-XX-B0-0000	DAML-10R-XX-SS0-00
400	22	SV-SH26-022B-4-XXX-XXXX	61	SV-DA200-022-4-XX-XXXX	22	66	DBEL-15-XX-B0-0000	DAML-10R-XX-SS0-00	

/ Other INVTT industrial control products



■ PLC

- Complete product categories for wide application
- Abundant extension modules for easy function extension
- Support various communication protocol, flexible networking
- Delicate volume for easy maintenance



■ HMI

- Plentiful display interfaces, strong system configuration function
- Visual software for convenient configuration



■ Motion controller

- Various motion controller card
- All series motion controller
- Robot control system
- Customized numerical control system



■ Inverter

- The most comprehensive inverter lines in the industry, covering from low, medium to high voltage inverters
- Customized products based on customer needs are available



■ Self-start motor

- IE4 energy efficiency grade, high efficiency and high power factor
- Direct grid, asynchronous start-up, shift to synchronous operation in extremely short time
- Built-in temp protection device. Adopt coaxial fan with excellent heat dissipation effect. No demagnetization during normal motor operation

BETTER SERVO | BETTER SOLUTION

Perfect combination of servo and system solution



Scan above QR code to visit INVT official website



Service line: 400-700-9997 Website: www.invt-tech.com

INVT INDUSTRIAL TECHNOLOGY (SHANGHAI) CO.,LTD.

No. 1 Building, No. 188 New Junhuan Road, Pujiang High Tech Park, Minhang District, Shanghai

Industrial Automation: ■ Inverter ■ **Servo System** ■ Motor & Electric Spindle ■ Electronic control system
■ HMI ■ PLC ■ Traction System ■ Intelligent Elevator Control System

Electric Power ■ SVG ■ Solar Inverter ■ UPS ■ Online Energy Management System ■ New engery vehicle electro-control system